



**CMA-1**  
**Installation Instructions**



**PLEASE NOTE:** Read the enclosed warranty statement before installation.

Installation of the CMA-1 is complex and should not be attempted by anyone without the proper tools or knowledge. This amplifier is intended for state-of-the-art mobile fidelity and requires state-of-the-art installation methods for full benefits.

**\*\*CAUTION\*\***

Because this amplifier can draw extremely large current from the battery, the standard automobile charging system may not be sufficient. Even With the engine running, the amplifier may draw enough current to discharge the battery. The owner/operator should consider installing a higher-ampereage alternator and a secondary battery. Power consumption is 73 amps DC maximum, 10-40 amps DC nominal at 12-14 VDC.

Use only a minimum size of #8 gauge stranded cable (#6 recommended) between the battery and the CMA-1, for both positive and negative leads, with no splices. Thinner cable may overheat and cause a fire. Thinner cable also reduces the 12VDC power available to drive the unit, thus reducing total output power and performance. Use of a cable smaller than #8 gauge could void the warranty.

Number 6 gauge stranded cable is highly recommended for lengths over 12 feet or with installations demanding the highest possible performance from the amplifier. Use cable intended specifically for automotive use.

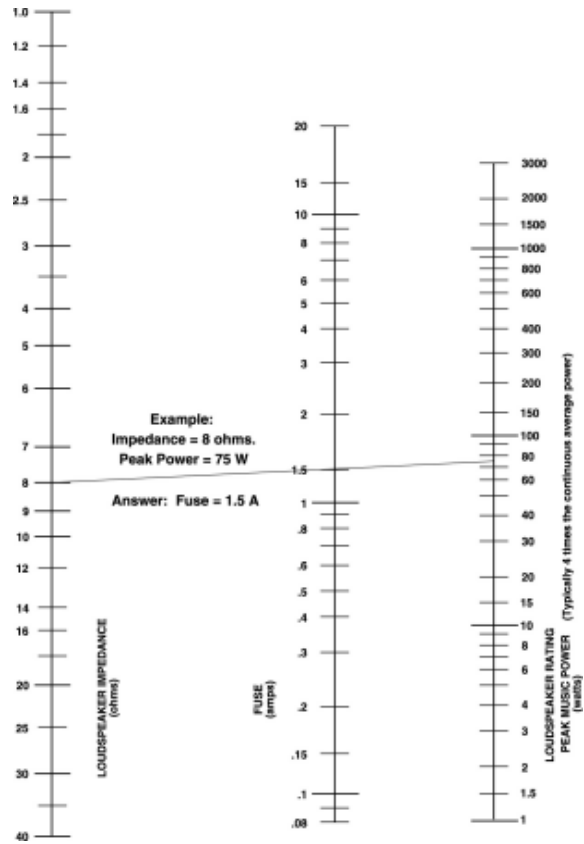

Fig. 1 Fuse-Size Nomograph

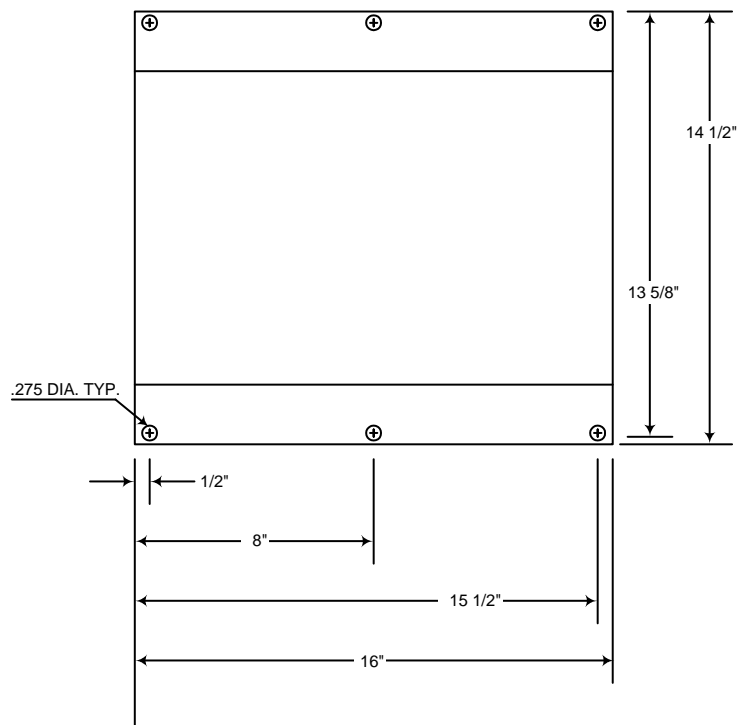

Fig 2 CMA-1 Mounting-Hole Locations

## **\*\*Caution\*\***

It is very important to install a 60-amp fuse in the +12VDC power wire at the battery. This fuse prevents fires caused by wiring shorts to the vehicle chassis due to improper installation or unforeseen accidents.

As in any professional installation, fusing the speaker lines is highly recommended to protect the speakers. Refer to **Figure 1** to determine proper speaker-fuse values.

If speaker cables must be spliced to shorten or lengthen them, the splices must be mechanically and electrically sound. Simply twisting wires together and wrapping with electrical tape is not adequate. We strongly recommend insulated crimped terminals, wire nuts wrapped with electrical tape, or solder connections with wire nuts wrapped with electrical tape.

Avoid pinching or piercing the speaker cable during installation. Route speaker cables separate from amplifier- input cables to prevent oscillations. Observe proper polarity of plus and minus wires when adding wire.

Due to extreme output power, the CMA-1 could, when abused, damage certain models of loudspeakers. Use speakers that can handle the amplifier power output. After installation, turn up the volume slowly and avoid overdriving the speakers.

**Accessories Supplied:** The CMA-1 comes complete with:

- 60-amp fuse
- Fuse Holder
- Input cable harness
- Remote on/off cable

**Mounting:** Mount the CMA-1 securely, say to the vehicle chassis or to a wooden panel. Allow adequate airspace (at least 1") and sufficient airflow around the heat fins for cooling. The CMA-1 may be mounted horizontally or vertically in the trunk or behind rear car seats. **DO NOT** place the CMA-1 in the engine compartment or in an area exposed to a harsh environment. Do not mount near the vehicle heater.

Dimensions of the CMA-1 are 16"L x 14-1/2"W x 1-5/8"H. Mounting-hole locations are shown in **Figure 2**. The amplifier can be used as a hole template.

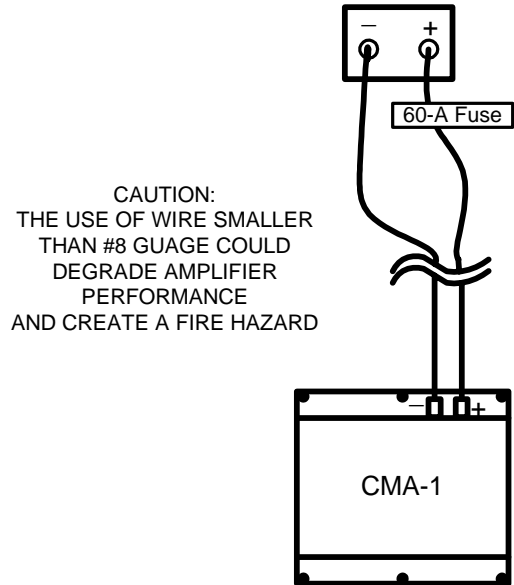

Fig. 3 Power-Wiring Connections

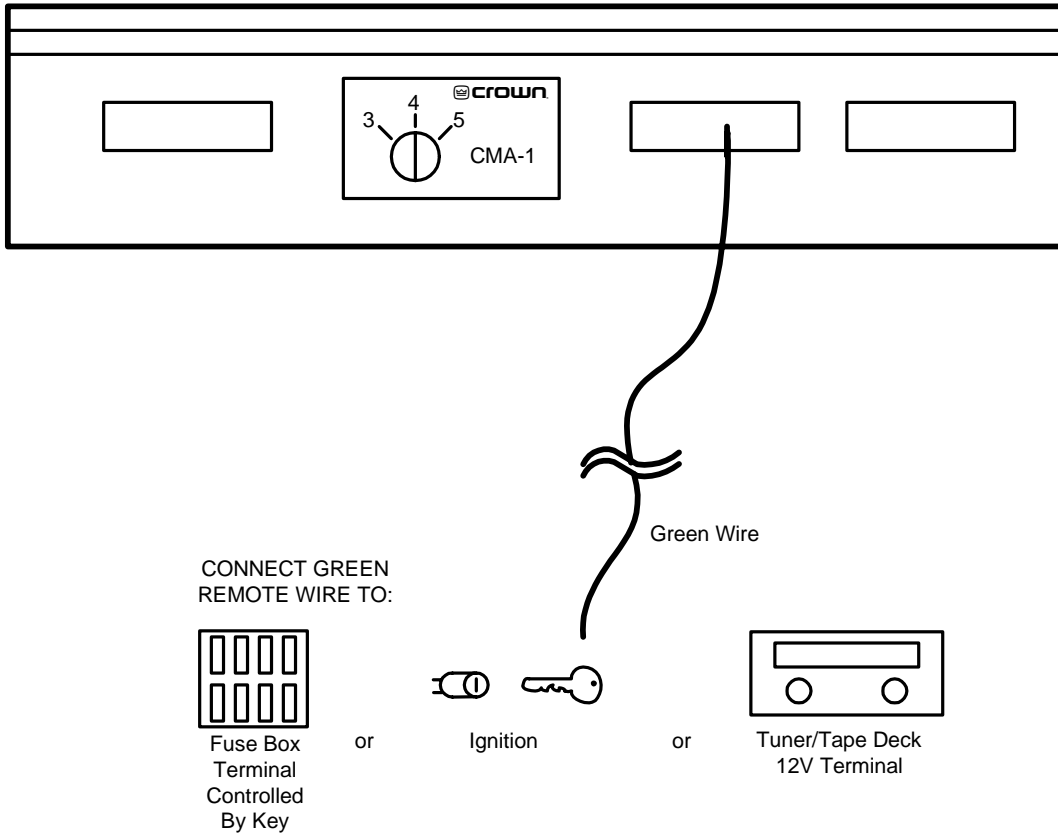

Fig. 4 Remote On/Off Wire Connection

### POWER WIRING: (refer to Figure 3)

1. Before beginning installation, disconnect the Positive (+) battery power cable. Do not re-connect the power cable until installation is complete.
2. Using only the minimum size #8 stranded cable (#6 recommended) with a terminal on the battery end, connect the CMA-1 terminal marked “-“ to the negative (-) terminal of the battery. Do not splice the cable. **Connecting this cable anywhere other than the battery is not acceptable** (i.e., don’t connect to the vehicle fuse block because the CMA-1 current draw could melt the vehicle’s wire harness!)
3. Using ONLY the minimum size #8 stranded cable (#6 recommended) with a terminal on the end, connect the CMA-1 terminal marked “+” to the positive (+) battery cable terminal you just removed. Do not splice the cable (except for the fuse holder). **Connecting this cable anywhere other than the battery is not acceptable.**  
If you’re using the same cable for both the positive and negative connections, clearly mark the positive cable to prevent miswiring. Improper connection could damage the amplifier, battery or electrical system.
4. Install the supplied 60-amp fuse in the Positive (+) cable near the battery. Failure to install the fuse could result in vehicle fire due to accidental shorting of the power cables.

### REMOTE ON/OFF WIRING (Refer to Figure 4)

1. Turn down your sound system volume to minimum.
2. The green “remote” wire on the CMA-1 is, in effect, the on/off switch of the amplifier. Connect the green remote wire to the switched +12 VDC supply, either through the ignition key, the tape deck/tuner, or a switched terminal at the fuse box. Some tuners have a switched +12v terminal for this purpose.  
Do not confuse the green remote wire with the green speaker wire (see **Figure 4**).  
DO NOT connect the green wire to the main +12VDC power supply lead or other continuously “hot” sources; this will cause the amplifier to be continuously on and will drain the battery.
3. DO NOT turn on the power until the speaker cables are installed (described later)

## **MULTI-CHANNEL OPTIONS**

The CMA-1 has a switch-selectable multi channel format offering the following choices:

3 Channel: 3x100 W

4 Channel: 2x100 W plus 2x50 W

5 Channel: 1x100 W plus 4x50 W

This unusual flexibility allows for 2-channel plus sub woofer, as well as other variations for custom installations.

**NOTE:** The CMA-1 inputs are high-impedance line-level inputs. Speaker outputs from the car radio should NOT be wired into this amplifier.

When connecting tuner/tape deck outputs to the CMA-1 inputs, use an appropriate connector, or solder the connections and insulate them with electrical tape. All connections must be mechanically and electrically secure to prevent problems.

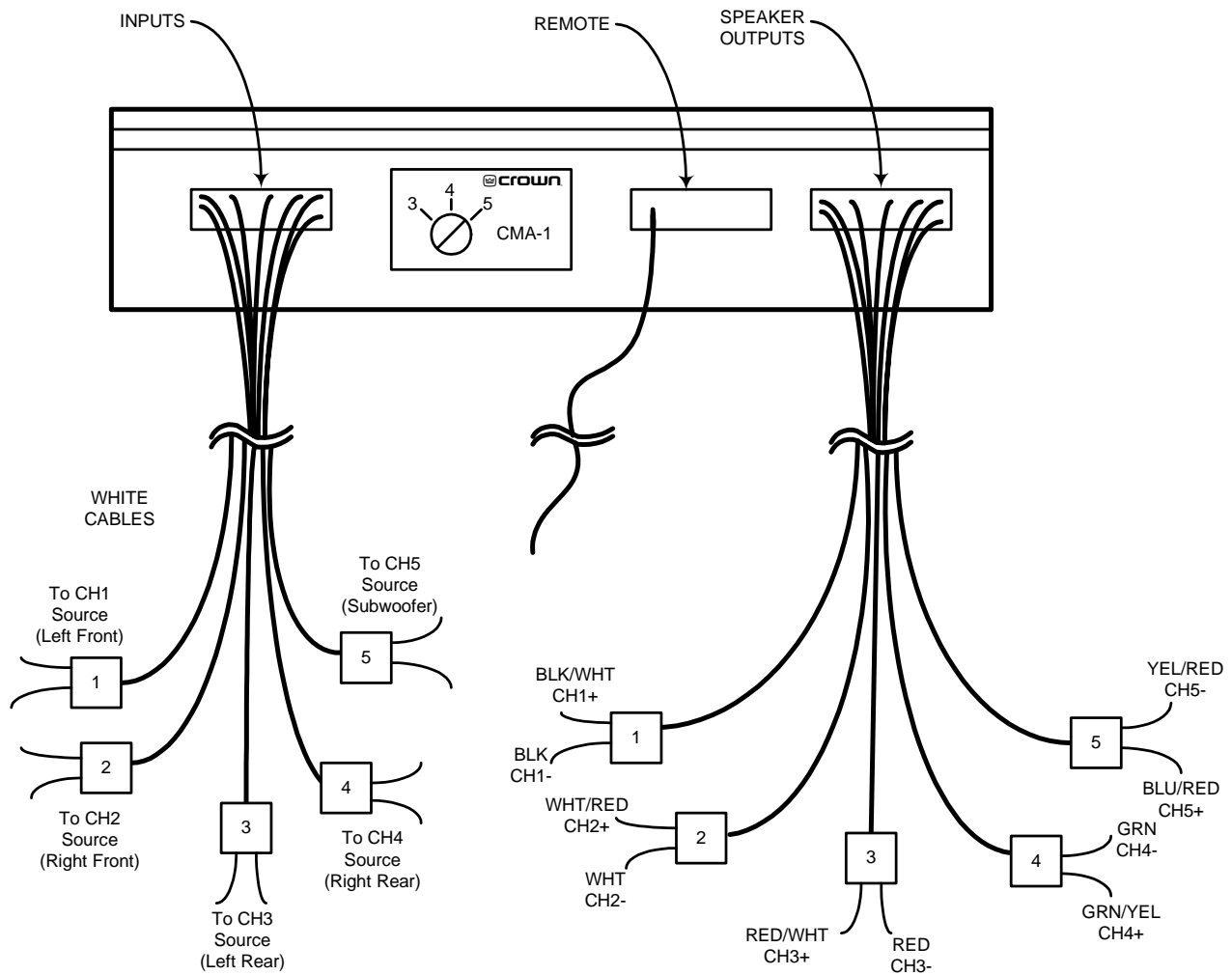

Fig. 5 5-Channel Connections

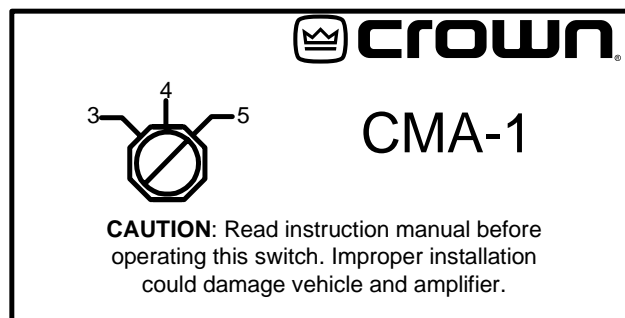

Fig. 6 Switch Position for 5 CH Operation



## 5-CHANNEL WIRING

The amplifier inputs are white cables. Each cable is marked with a numbered band at the end of the cable.

1. Refer to **Figure 5** for the following connections:

Connect CH 1 signal (left-front) to white input cable 1.  
Connect CH2 signal (right-front) to white input cable 2.  
Connect CH3 signal (left-rear) to white input cable 3.  
Connect CH4 signal (right-rear) to white input cable 4.  
Connect CH5 signal (Subwoofer) to white input cable 5.

2. Set the amplifier switch to 5 CH as in **Figure 6**. This provides the following output powers:

CH1: 50 W at 4 ohms  
CH2: 50 W at 4 ohms  
CH3: 50 W at 4 ohms  
CH4: 50 W at 4 ohms  
CH5: 100 W at 8 ohms

(These are minimum recommend loads.)

3. Refer to **Figure 5**. Connect the speakers as follows. Route the CMA-1 colored output cables separate from its white input cables to prevent oscillations. Using crimp terminals, connect the CMA-1 colored cables to the speaker terminals, taking care to observe the cables colors and polarities noted below:

Blk/Wht:	CH 1 +	Left-Front Speaker
Blk:	CH 1 -	
Wht/Red:	CH 2 +	Right-Front Speaker
Wht:	CH 2 -	
Red/Wht:	CH 3 +	Left-Rear Speaker
Red:	CH 3 -	
Grn/Yel:	CH 4 +	Right-Rear Speaker
Grn:	CH 4 -	
Blu/Red:	CH 5 +	Subwoofer
Yel/Red:	CH 5 -	

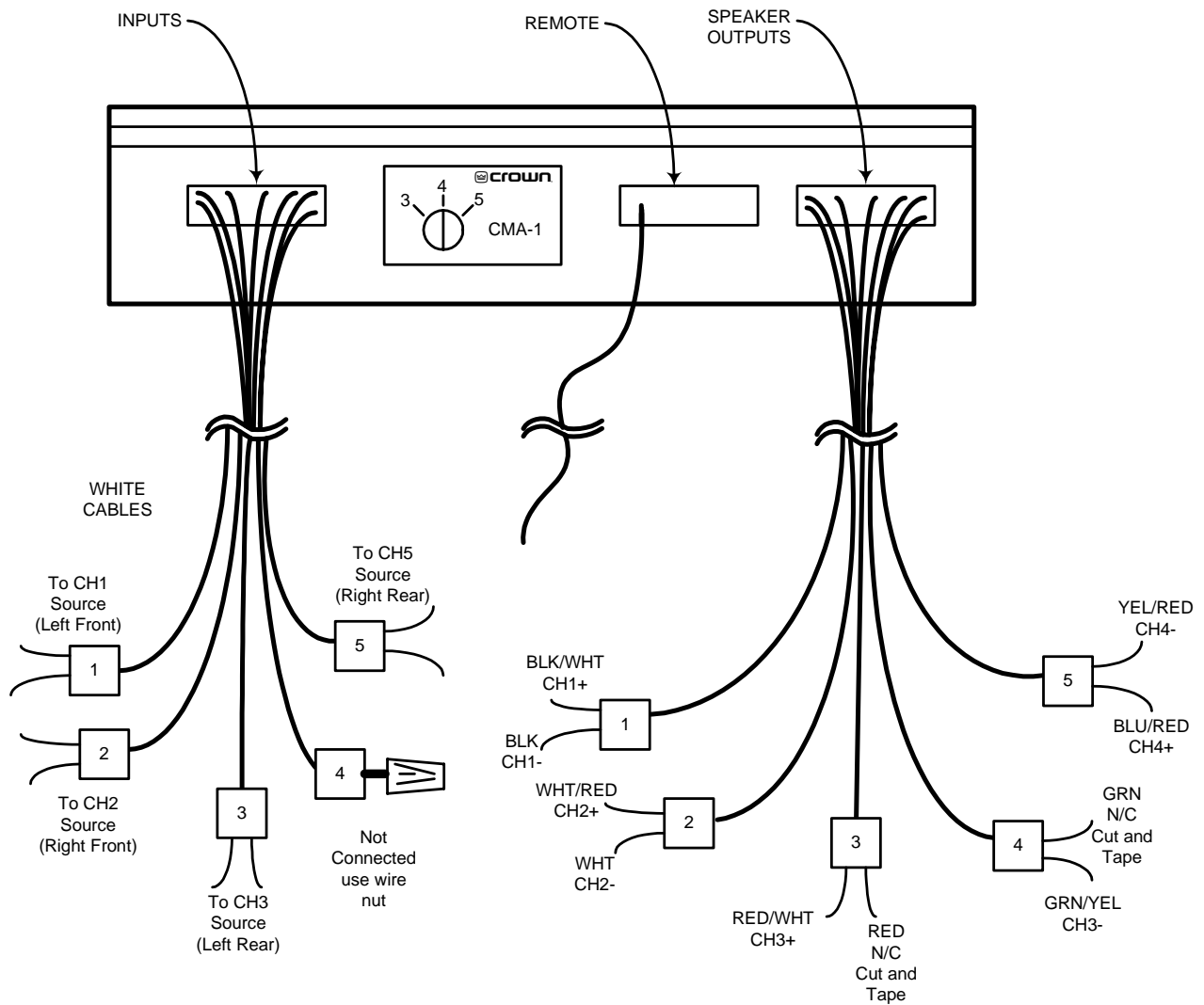

Fig. 7 4-Channel Connections

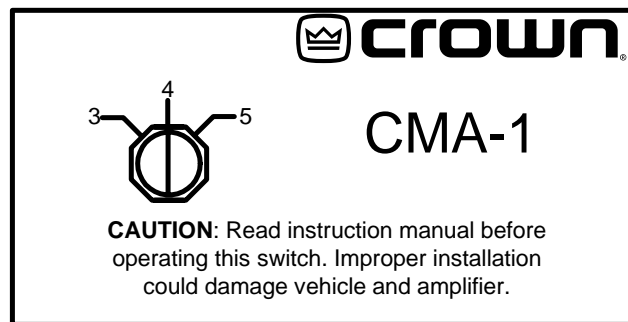

Fig. 8 Switch Position for 4 CH Operation

## 4-CHANNEL WIRING

The amplifier inputs are white cables. Each cable is marked with a numbered band at the end of the cable.

1. Refer to **Figure 7** for the following connections:

Connect CH 1 signal (left-front) to white input cable 1.  
Connect CH2 signal (right-front) to white input cable 2.  
Connect CH3 signal (left-rear) to white input cable 3.  
Connect CH4 signal (right-rear) to white input cable 5.

NOTE: White input cable 4 is not used. To avoid accidental shorting of this cable to the chassis, and to reduce noise, use a wire nut to connect the “hot lead” and shield in white cable 4.

2. Set the amplifier switch to 4 CH as in **Figure 8**. This provides the following output powers:

CH1: 50 W at 4 ohms  
CH2: 50 W at 4 ohms  
CH3: 100 W at 8 ohms  
CH4: 100 W at 8 ohms

(These are minimum recommend loads.)

3. Refer to **Figure 7**. Connect the speakers as follows. Route the CMA-1 colored output cables separate from its white input cables to prevent oscillations. Using crimp terminals, connect the CMA-1 colored cables to the speaker terminals, taking care to observe the cables colors and polarities noted below:

Blk/Wht:	CH 1 +	Left-Front Speaker
Blk:	CH 1 -	
Wht/Red:	CH 2 +	Right-Front Speaker
Wht:	CH 2 -	
Red/Wht:	CH 3 +	Left-Rear Speaker or Left Subwoofer
Grn/Yel:	CH 3 +	
Blu/Red:	CH 4 +	Right-Rear Speaker or Right Subwoofer
Yel/Red:	CH 4 -	

NOTE: The Red and Green cables are not used. To avoid accidental shorting of these cables, clip exposed ends back to the insulation, and cover with electrical tape.

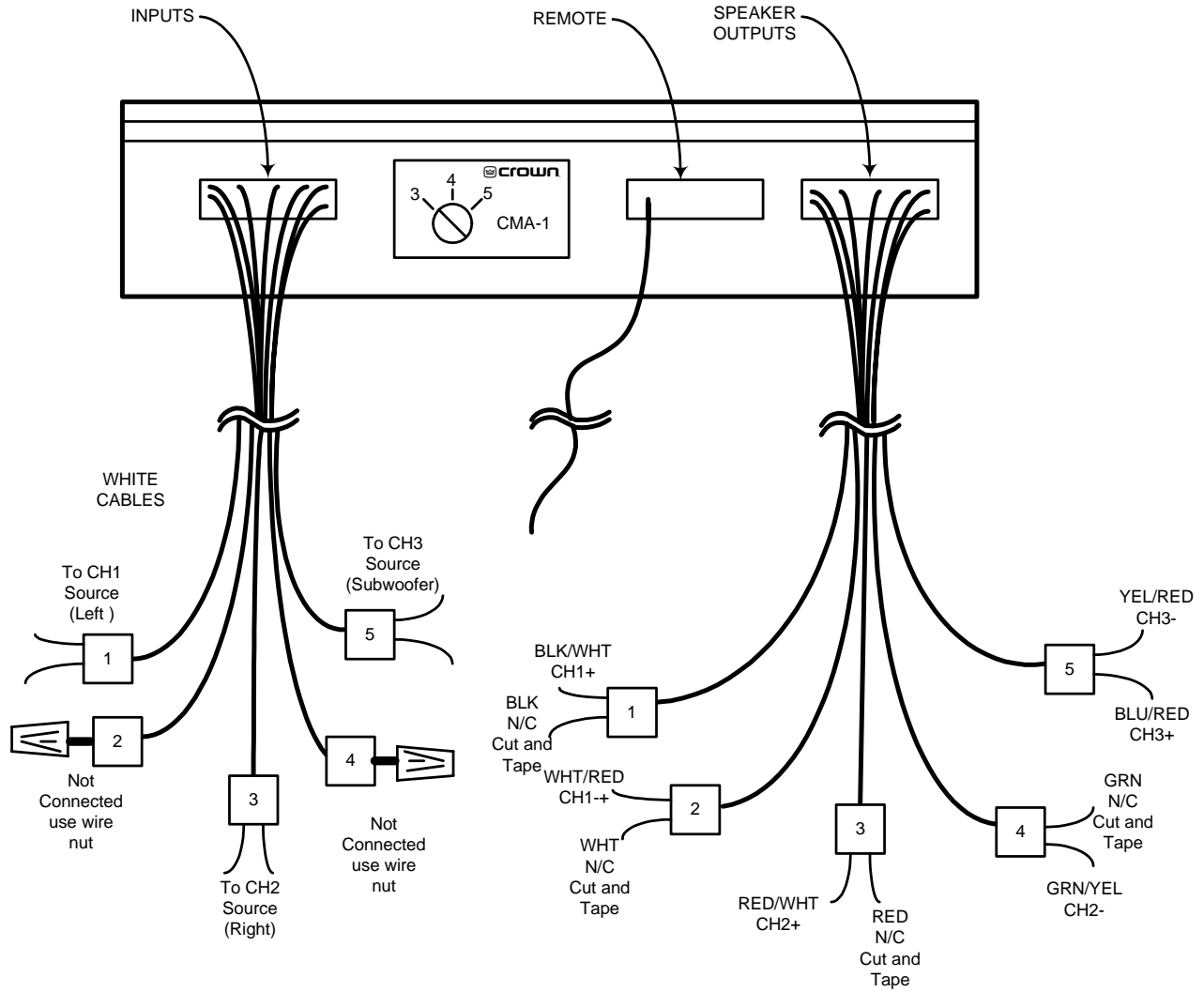

Fig. 9 3-Channel Connections

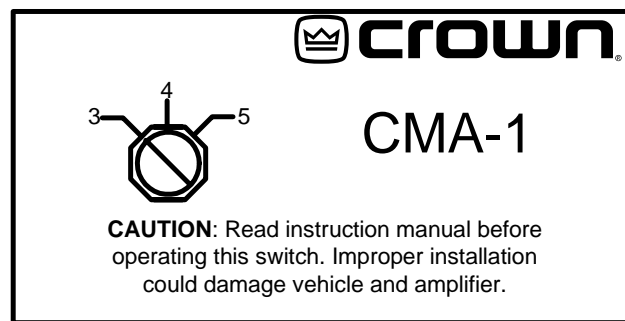

Fig. 10 Switch Position for 3 CH Operation

### 3-CHANNEL WIRING

The amplifier inputs are white cables. Each cable is marked with a numbered band at the end of the cable.

1. Refer to **Figure 9** for the following connections:

Connect CH 1 signal (left) to white input cable 1.  
Connect CH2 signal (right) to white input cable 2.  
Connect CH3 signal (Subwoofer) to white input cable 5.

NOTE: White input cables 2 and 4 are not used. To avoid accidental shorting of these cables to the chassis, and to reduce noise, use a wire nut to connect the “hot lead” and shield in each cable.

2. Set the amplifier switch to 3 CH as in **Figure 10**. This provides the following output powers:

CH1: 100 W at 8 ohms  
CH2: 100 W at 8 ohms  
CH3: 100 W at 8 ohms

(These are minimum recommend loads.)

3. Refer to **Figure 9**. Connect the speakers as follows. Route the CMA-1 colored output cables separate from its white input cables to prevent oscillations. Using crimp terminals, connect the CMA-1 colored cables to the speaker terminals, taking care to observe the cables colors and polarities noted below:

Blk/Wht:	CH 1 +	Left Speaker
Wht/Red:	CH 2 +	
Red/Wht:	CH 2 +	Right Speaker
Grn/Yel:	CH 2 +	
Blu/Red:	CH 3+	Subwoofer
Yel/Red:	CH 3 -	

NOTE: The Back, White, Red and Green cables are not used. To avoid accidental shorting of these cables, clip exposed ends back to the insulation, and cover with electrical tape.

## **OPERATION:**

1. After all connections are made, double check all connections to make sure they are mechanically and electrically sound. Verify correct polarity of all cables.
2. Check that there are no shorts to the vehicle chassis.
3. Check that the CMA-1 input and output cables are routed separate from each other.
4. Connect the positive battery-cable terminal to the battery. This terminal should already have the CMA-1 positive cable attached to it.
5. The CMA-2 has no level controls to preset. All level adjustment is done at the front end of the sound system.
6. With your sound system volume turned all the way DOWN, apply power to the CMA-1 by turning on your ignition key or tape deck/tuner.
7. After the 5-second turn-on delay, slowly turn up the volume, and enjoy your music! Avoid overdriving the speakers.

## **TROUBLESHOOTING:**

### NO SOUND FROM ALL SPEAKERS OR SOME SPEAKERS:

1. Recheck cable connections and routing according to this instruction sheet.
2. Check the fuse in-line with the +12VDC power cable. If the fuse is blown, find and repair the cable short to the vehicle frame. Replace the fuse with the same value fuse.

### DISTORDED (GRITTY) SOUND:

1. Turn down the volume of your sound system.
2. Turn down the bass of your sound system.
3. Turn down the low-frequency control(s) on your graphic equalizer.
4. Recheck cable connections at the speaker terminals for shorts. Check that the CMA-1 colored output cables are routed separately from its white input cables.

### STATIC (RADIO INTERFERENCE, IGNITION, NOISE):

1. Recheck all connections.
2. Use radio-suppressor spark-plug cables.
3. Use resistor-type spark plugs.
4. Check that all external equipment such as radios, tape decks, equalizers, and electronic crossovers have one main ground point.
5. Try to pin point the source of the static, such as the radio, equalizer, crossover or power amp. Make sure that these units are not defective.
6. Check for proper antenna grounding.

7. If the ignition system uses a distributor with points, check the capacitor on the distributor and also the capacitor on the coil.
8. Try re-routing the input and output cables.
9. Check for a bad alternator.
10. Make sure all power-cable connections are tight and secure.
11. Re-route the power cables.

**Service Policies:**

Due to the sophisticated circuitry of the CMA-1, only qualified, fully trained technicians should be allowed to service it.

**Specifications:**

Output Power: (20Hz-20kHz):

3 Channel Mode:	3x100W @ 8 ohms	.1% THD
4 Channel Mode:	2x50W @ 4 ohms	.05% THD
	2x100W @ 8 ohms	.1% THD
5 Channel Mode:	4x50W @ 4 ohms	.05% THD
	1x100W @ 8 ohms	.1% THD

	<u>Rated</u>	<u>Typical</u>
Frequency Response		
20Hz-20kHz at 1 watt:	+/- 1dB	+/- .5dB
THD at 50W	.05%	.04%
at 100W (Bridged)	.1%	.08%
S/N Ratio:	90dB	100dB
Damping Factor		
50Hz-1kHz:	50	100
Input Sensitivity:	.775V	
Input Impedance:	>10K ohm	
Supply Voltage:	12-14 VDC	
Power Consumption:	73 amps DC max.	
	10-40 amps DC nominal	
Size:	16"L x 14-1/2"W x 3-5/8"H	
Weight:	20 lbs.	

# # #