

Studio Reference™ Service Manual

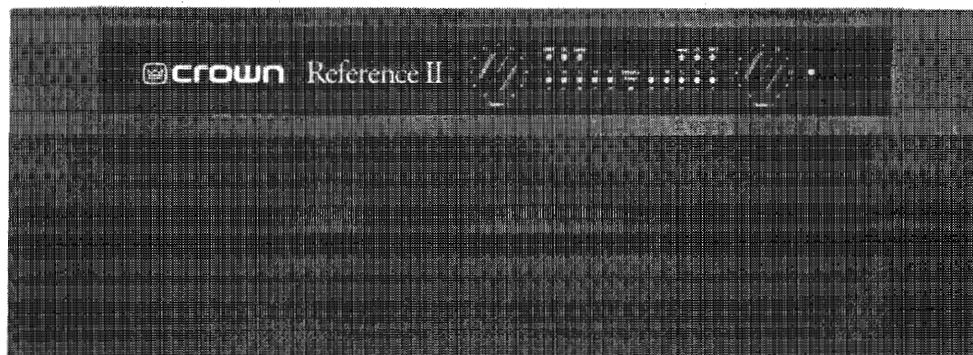
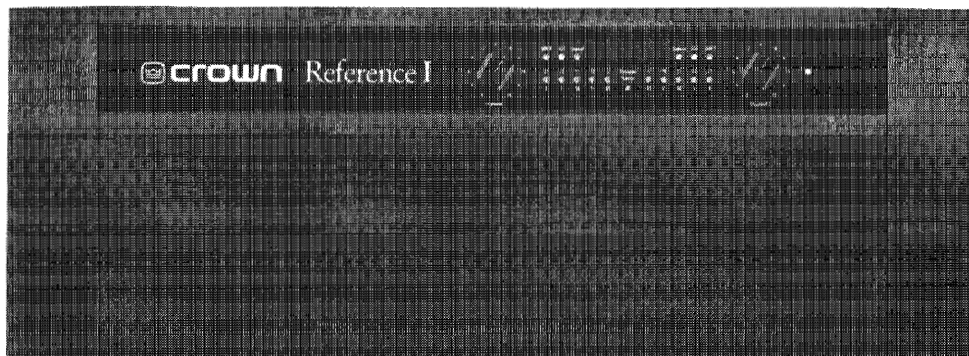

PROFESSIONAL STUDIO AMPLIFIERS

Models:

Studio Reference I & Studio Reference II

Some models may be exported under the name *Amcron*®

© 1998 by Crown International, Inc., P.O. Box 1000, Elkhart, Indiana 46515-1000 U.S.A. Telephone: 219-294-8000. *Studio Reference* amplifiers are produced by Crown International, Inc. Trademark Notice: *Studio Reference*™ and *Grounded Bridge*™ are trademarks and *Amcron*®, *Crown*®, *IOC*®, *ODEP*®, *IQ System*®, and *P.I.P.*® are registered trademarks of Crown International, Inc. Other trademarks are the property of their respective owners.

The information furnished in this manual does not include all of the details of design, production, or variations of the equipment. Nor does it cover every possible situation which may arise during installation, operation or maintenance. If you need special assistance beyond the scope of this manual, please contact the Crown Technical Support Group.

Mail: P.O. Box 1000 Elkhart IN 46515-1000
Shipping: Pkt. 2 S.W., 1718 W. Mishawaka Rd., Elkhart IN 46517
Phone: (800) 342-6939/(219) 294-8200
FAX: (219) 294-8301
Web: www.crownaudio.com

CAUTION

TO PREVENT ELECTRIC SHOCK DO NOT REMOVE TOP OR BOTTOM COVERS. NO USER SERVICEABLE PARTS INSIDE. REFER SERVICING TO QUALIFIED SERVICE PERSONNEL. DISCONNECT POWER CORD BEFORE REMOVING REAR INPUT MODULE TO ACCESS GAIN SWITCH.

AVIS

À PRÉVENIR LE CHOC ÉLECTRIQUE N'ENLEVEZ PAS LES COUVERTURES. RIEN DES PARTIES UTILES À L'INTÉRIEUR. DÉBRANCHER LA BORNE AVANT D'OUVRIER LA MODULE EN ARRIÈRE.

**WARNING**

TO REDUCE THE RISK OF ELECTRIC SHOCK, DO NOT EXPOSE THIS EQUIPMENT TO RAIN OR MOISTURE!

Revision History

Revision Number	Date	Changes
Rev. 0	12-98	Initial Printing

This page intentionally left blank

Table of Contents

1 Introduction	1-1
1.1 The Studio Reference	1-1
1.2 Scope	1-1
1.3 Warranty	1-1
2 Specifications	2-1
2.1 Performance	2-1
2.2 Power	2-1
2.3 Controls	2-2
2.4 Indicators	2-2
2.5 Input/Output	2-3
2.6 Output Signal	2-3
2.7 Protection	2-3
2.8 Construction	2-3
3 Voltage Conversion	3-1
4 Circuit Theory	4-1
4.1 Overview	4-1
4.2 Features	4-2
4.3 Front End Operation	4-2
4.3.1 Balanced Gain Stage (BGS)	4-2
4.3.2 Variable Gain Stage (VGS)	4-2
4.3.3 Error Amp	4-2
4.4 Voltage Amplification	4-2
4.4.1 Voltage Translators	4-3
4.4.2 Last Voltage Amplifiers (LVAs)	4-3
4.5 Grounded Bridge Topology	4-4
4.5.1 High Side (HS)	4-4
4.5.2 Low Side (LS)	4-4
4.6 Output Device Emulation Protection (ODEP)	4-5
4.7 Control Circuitry	4-6
4.7.1 DC/LF Protect	4-6
4.7.2 Fault Circuit	4-6
4.7.3 Turn On Delay	4-6
4.7.4 Fan Control	4-6
4.8 Power Supply	4-6
4.8.1 AC Line Filter	4-6
4.8.2 Soft Start	4-6
4.8.3 Over Voltage Protection	4-7
4.9 Display Circuitry	4-7
4.9.1 IOC	4-7
4.9.2 ODEP	4-7
4.9.3 Signal Indication	4-7

Table of Contents

5 Electrical Checkout and Adjustment Procedures	5-1
5.1 General Information	5-1
5.2 Standard Initial Conditions	5-1
5.3 DC Offset	5-1
5.4 Output Bias Adjustment	5-1
5.5 ODEP Voltage Adjustment	5-1
5.6 AC Power Draw	5-1
5.7 High Line Cutout	5-1
5.8 Common Mode Rejection	5-1
5.9 Voltage Gain	5-2
5.10 Level Controls	5-2
5.11 Current Limit	5-2
5.12 Slew Rate and 10K Square Wave	5-2
5.13 Crosstalk	5-3
5.14 Output Power	5-3
5.15 Reactive Loads	5-3
5.16 ODEP Limiting	5-4
5.17 Mute and Turn-On Delay	5-4
5.18 Low Frequency Protection	5-4
5.19 Signal to Noise Ratio	5-5
5.20 Intermodulation Distortion	5-5
5.21 LED Functions	5-5
5.22 Display Set-Up	5-5
5.23 Turn-On Transients	5-5
5.24 Turn-Off Transients	5-5
5.25 Post Testing	5-5
6 Schematics	6-1
7 Parts Information	7-1
7.1 General Information	7-1
7.2 Standard and Special Parts	7-1
7.3 Ordering Parts	7-1
7.4 Shipment	7-1
7.5 Terms	7-1
7.6 Illustrated Parts List	7-1
Figure 7.1 Front Panel Exploded View	7-2
Figure 7.2 Top Main Assembly Exploded View	7-4
Figure 7.3 Bottom Main Assembly Exploded View	7-6
Figure 7.4 Back Panel Assembly Exploded View	7-8
Figure 7.5 Output Assembly Exploded View	7-10
Figure 7.6 Capacitor Assembly Exploded View	7-12
Figure 7.7 PIP Cage Assembly Exploded View	7-15

Table of Contents

8 Module Information	8-1
8.1 General Information	8-1
8.2 Studio Reference I Module Information	8-1
8.3 Studio Reference II Module Information	8-1
8.4 Q43371-6 Main Module	8-2
8.5 Q43369-0 Output Module	8-8
8.6 Q43183A3 Control Module	8-11
8.7 Q43450-8 Control Module	8-14
8.8 Q43504-2 Control Module	8-17
8.9 Q43018-3 Display Module	8-20
8.10 Q43311-2 Main Module	8-23
8.11 Q43388-0 Main Module	8-28
8.12 Q43389-8 Output Module	8-33
8.13 Q43312-0 Display Module	8-36

List of Illustrations

Figure 2.1 Studio Reference Dimensions	2-3
Figure 3.1 Specific Voltage Wiring	3-1
Figure 3.2 Circuit Breaker Selection	3-1
Figure 4.1 Simplified Studio Reference Block Diagram	4-1
Figure 4.2 Simplified Amplifier Front End and Voltage Amplification Stages ..	4-3
Figure 4.3 Simplified Grounded Bridge	4-5
Figure 5.1 Differentiator Circuit	5-2
Figure 5.2 Differentiated Square Wave	5-2
Figure 5.3 10 kHz Square Wave	5-2
Figure 5.4 Inductive Load Cold	5-3
Figure 5.5 Inductive Load Warm	5-3
Figure 5.6 Torture Test Waveform	5-4
Figure 5.7 ODEP Limiting Waveform	5-4
Figure 7.1 Front Panel Parts	7-2
Figure 7.2 Top Main Assembly Parts	7-4
Figure 7.3 Bottom Main Assembly Parts	7-6
Figure 7.4 Back Panel Assembly Parts	7-8
Figure 7.5 Output Assembly Parts	7-10
Figure 7.6 Capacitor Assembly Parts	7-12
Figure 7.7 PIP Cage Assembly Parts	7-14
Figure 8.1 Q43371-6 Main Module Map	8-7
Figure 8.2 Q43369-0 Output Module Map	8-10
Figure 8.3 Q43183A3 Control Module Map	8-13
Figure 8.4 Q43450-8 Control Module Map	8-16
Figure 8.5 Q43504-2 Control Module Map	8-19
Figure 8.6 Q43018-3 Display Module Map	8-22
Figure 8.7 Q43311-2 Main Module Map	8-27
Figure 8.8 Q43388-0 Main Module Map	8-32
Figure 8.9 Q43389-8 Output Module Map	8-35
Figure 8.10 Q43312-0 Display Module Map	8-38

1 Introduction

1.1 The Studio Reference

The Studio Reference amplifiers are the flagship of Crown International. They offer the best in sound reproduction with a dynamic range capable of accurately reproducing 20-bit digital recordings. Super low harmonic and intermodulation distortion provides the best transfer function in the business. And the ultra-high damping factor of 20,000 delivers superior loudspeaker motion control for a tight and clean low-end.

1.2 Scope

This manual contains service information for the Crown Studio Reference power amplifiers. It is designed to be used with the applicable Reference Manual. However, some important information is duplicated in this Service Manual in case the Reference Manual is not readily available.

This Service Manual includes several sections. These sections include Specifications, Voltage Conversion, Circuit Theory, Electrical Checkout, Parts Information, Module Information, and Exploded View Drawings.

Schematics are included. Note that a Module is comprised of the circuit board with the component parts installed. Crown does not sell blank (unpopulated) circuit boards.

CAUTION: The information in this manual is intended to be used by an experienced technician only!

1.3 Warranty

Each Reference Manual contains basic policies as related to the customer. In addition, it should be stated that this service documentation is meant to be used only by properly trained service personnel. Because most Crown products carry a 3 Year Full Warranty (including round trip shipping within the United States), all warranty service should be referred to the Crown Factory or Authorized Warranty Service Center. See the applicable Owner's Manual for warranty details. To find the location of the nearest Authorized Service Center, or to obtain instructions for receiving Crown Factory Service, please contact the Crown Technical Support Group (within North America) or your Crown/Amcron Importer (outside North America).

Crown
Technical Support Group
Factory Service
Parts Department

Mailing Address:

PO Box 1000
Elkhart, IN USA 46515-1000

Shipping Address:

Plant 2 S.W.
1718 W. Mishawaka Rd.
Elkhart, IN USA 46517

Phone: (219) 294-8200

Toll Free: (800) 342-6939

FAX: (219) 294-8301

Web: www.crownaudio.com

This page intentionally left blank

2 Specifications

The following specifications apply to units in Stereo Mode, with an 8 Ohm load, and an input sensitivity of 26dB, unless otherwise specified.

Low-Distortion 1 kHz Power: Refers to maximum average power in watts at 1 kHz with 0.02% THD and noise.

Standard 1 kHz Power: Refers to maximum average power in watts at 1 kHz with 0.1% THD and noise.

Full Bandwidth Power: Refers to maximum average power in watts from 20 Hz to 20 kHz with 0.1% THD and noise.

2.1 Performance

Frequency Response: ± 0.1 dB from 20 Hz to 20 kHz at 1 watt.

Phase Response: +5 to -15 degrees from 20 Hz to 20 kHz at 1 watt.

Signal-to-noise: (A-weighted)

Studio Reference I: Greater than 120 dB below full bandwidth power.

Studio Reference II: Greater than 117 dB below full bandwidth power.

Total Harmonic Distortion (THD): Less than 0.02% at rated low-distortion 1 kHz power. Less than 0.1% at rated full bandwidth power.

Intermodulation Distortion (IMD): (60 Hz & 7 kHz 4:1)

Studio Reference I: Less than 0.005% from full bandwidth power to 78 watts rising linearly to 0.025% at 78 milliwatts.

Studio Reference II: Less than 0.005% from full bandwidth power to 36 watts rising linearly to 0.025% at 36 milliwatts.

Damping Factor: Greater than 20,000 from 10 Hz to 200 Hz, and greater than 2,500 at 1 kHz.

Crosstalk: (At rated full bandwidth power.)

Studio Reference I: Better than 100 dB from 20 Hz to 100 Hz, falling linearly to better than 70 dB at 20 kHz.

Studio Reference II: Better than 100 dB from 20 Hz to 100 Hz, falling linearly to better than 65 dB at 20 kHz.

Common Mode Rejection (CMR): Better than 100 dB below rated full bandwidth power from 20 Hz to 400 Hz, rising linearly to better than 70 dB at 20 kHz.

Voltage Gain: (With level controls set for maximum output.) At the 26 dB gain setting, 20:1 $\pm 3\%$ or 26 dB ± 0.25 dB.

Studio Reference I: At 0.775 volt sensitivity, 103:1 $\pm 12\%$ or 40 dB ± 1 dB; at 1.4 volt sensitivity, 57:1 $\pm 12\%$ or 35 dB ± 1 dB.

Studio Reference II: At 0.775 volt sensitivity, 69:1 $\pm 12\%$ or 37 dB ± 1 dB; at 1.4 volt sensitivity, 38:1 $\pm 12\%$ or 32 dB ± 1 dB.

2.2 Power

Power Bandwidth: (At standard 1 kHz power.)

Studio Reference I: -1 dB from 5 Hz to 27.5 kHz and -3 dB from 3 Hz to 32.8 kHz.

Studio Reference II: -1 dB from 5 Hz to 28.6 kHz and -3 dB from 2.3 Hz to 34.4 kHz.

The following power ratings are for units configured for 120 VAC, 60 Hz. For information on power specifications for units configured for other voltages, see the reference manual.

Low-Distortion 1 kHz Output Power:

Studio Reference I:

Stereo Mode with both channels driven:

1,160 watts per channel into 4 ohms.

760 watts per channel into 8 ohms.

Bridge-Mono mode:

2,220 watts into 8 ohms.

1,580 watts into 16 ohms.

Parallel-Mono mode:

2,315 watts into 2 ohms.

1,565 watts into 4 ohms.

Studio Reference II:

Stereo Mode with both channels driven:

555 watts per channel into 4 ohms.

355 watts per channel into 8 ohms.

Bridge-Mono mode:

1,110 watts into 8 ohms.

715 watts into 16 ohms.

Parallel-Mono mode:

1,115 watts into 2 ohms.

710 watts into 4 ohms.

2 Specifications

Standard 1 kHz Output Power:

Studio Reference I:

Stereo mode with both channels driven:

1,190 watts per channel into 4 ohms.

800 watts per channel into 8 ohms.

Bridge-Mono mode:

2,375 watts into 8 ohms.

1,595 watts into 16 ohms.

Parallel-Mono mode:

2,350 watts into 2 ohms.

1,580 watts into 4 ohms.

Studio Reference II:

Stereo mode with both channels driven:

565 watts per channel into 4 ohms.

360 watts per channel into 8 ohms.

Bridge-Mono mode:

1,145 watts into 8 ohms.

720 watts into 16 ohms.

Parallel-Mono mode:

1,135 watts into 2 ohms.

715 watts into 4 ohms.

Full Bandwidth Output Power: (20 Hz to 20 kHz)

Studio Reference I:

Stereo mode with both channels driven:

1,075 watts per channel into 4 ohms.

760 watts per channel into 8 ohms.

Bridge-Mono mode:

2,150 watts into 8 ohms.

1,535 watts into 16 ohms.

Studio Reference II:

Stereo mode with both channels driven:

495 watts per channel into 4 ohms.

340 watts per channel into 8 ohms.

Bridge-Mono mode:

1,020 watts into 8 ohms.

690 watts into 16 ohms.

Load Impedance: Safe with all types of loads. Rated for 4 to 8 ohms in stereo mode, 8 to 16 ohms in Bridge-Mono mode, and 2 to 4 ohms in Parallel-Mono mode.

Required AC Mains: 50 or 60 Hz; 100, 120, 200, 220 or 240 VAC ($\pm 10\%$). Both units draw 90 watts or less at idle.

2.3 Controls

Enable: A front panel push button used to turn the amplifier on and off.

Level: A front panel rotary potentiometer for each channel with 31 detents, used to control the output level.

Stereo/Mono: A three-position back panel switch used to select either Stereo, Bridge-Mono or Parallel-Mono mode.

Sensitivity: A three-position switch inside the P.I.P. compartment used to select the input sensitivity for both channels: 0.775 or 1.4 volts for standard 1 kHz power, or 26 dB voltage gain.

Meter On/Off: A two-position switch behind the front panel used to turn the front panel meters on or off.

Meter Display Mode: A two-position switch behind the front panel used to set the display mode for the front panel meters. Display modes include dynamic range of the output signal in dB or output levels in dB.

Ground Lift: A two-position back panel switch used to isolate the input phone jack and AC (chassis) grounds.

Reset: A two-position back panel switch used to reset the AC mains circuit breaker.

2.4 Indicators

Enable: This indicator shows the on/off status of the unit's low-voltage power supply.

Signal: Each channel has a signal indicator that flashes to show audio output.

IOC: Each channel has an IOC indicator that flashes if the output waveform differs from the input waveform by 0.05% or more. The LEDs act as sensitive distortion indicators to provide proof of distortion-free performance. In Parallel-Mono mode the channel 2 IOC light stays on.

ODEP: Each channel has an ODEP indicator that shows the channel's reserve energy status. Normally, the LEDs are brightly lit to show that reserve energy is available. In the rare event that a channel has no reserve, its indicator will dim in proportion to ODEP limiting.

2 Specifications

Dynamic Range/Level Meter: Each Channel has a five-segment meter that displays either the dynamic range of the output signal in dB or the output level in dB. (From the factory, the amplifier is set to display dynamic range.) As dynamic range meters, they show the ratio of peak to average power of each channel. As output level meters they show how high the output levels are relative to standard 1 kHz power.

2.5 Input/Output

Input Connector: Two balanced 1/4-inch jacks on the back panel and two balanced three-pin XLR connectors on the factory-installed P.I.P.-FX.

Input Impedance: Nominally 10 K ohms, balanced. Nominally 5 K ohms, unbalanced.

Input Sensitivity: Settings include 0.775 volts or 1.4 volts for standard 1 kHz power, or 26 dB voltage gain.

Output Connectors: Two sets of color-coded 5-way binding posts for each channel (for connecting banana plugs, spade lugs or bare wire).

Output Impedance: Less than 10 milliohms in series with 2.5 microhenries.

DC Output Offset: (Shorted input) ± 2 millivolts.

2.6 Output Signal

Stereo: Unbalanced, two-channel.

Bridge-Mono: Balanced, single-channel. Channel 1 controls are active; channel 2 should be turned down.

Parallel-Mono: Unbalanced, single-channel. Channel 1 controls are active; channel 2 is bypassed.

2.7 Protection

ODEP: If unreasonable operating conditions occur which could stress the output circuitry, the ODEP circuit limits the output current level until safe operating conditions exist.

Transformer: Transformer overheating will result in a temporary shut-down due to a thermal switch in the transformer primary.

RF Burnout: Controlled slew-rate voltage amplifiers protect the unit against RF burnouts.

Input: Input overload protection is furnished at the amplifier input to limit current.

Turn On: The four second turn-on delay prevents dangerous turn-on transients.

2.8 Construction

Steel chassis with durable black finish, aluminum front panel with super-gloss Imron finish, Lexan overlay, and a specially designed flow-through ventilation system from front to side panels.

Cooling: Convection cooling with assistance from the computerized, on-demand proportional cooling fan.

Dimensions: Standard 19 inch (48.3 cm) rack mount width (EIA RS-310-B), 7 inch (17.8 cm) height, 16 inch (40.6 cm) depth behind mounting surface and 2.75 inch (7 cm) protrusion in front of mounting surface (see Fig. 2.1 below).

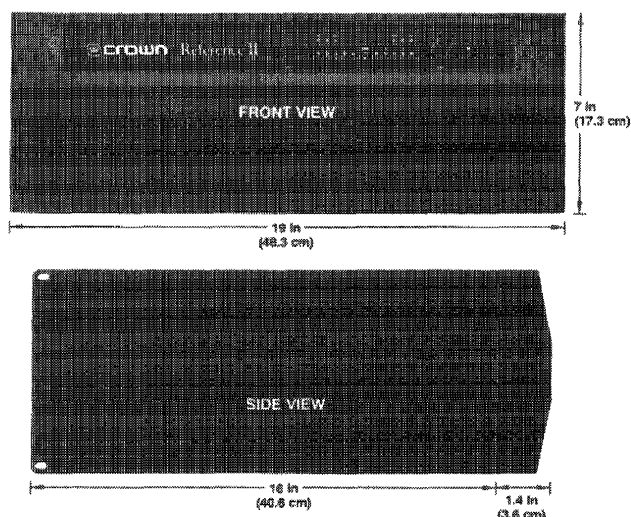

Figure 2.1: Studio Reference Dimensions

Approximate Weight: Center of gravity is about 6 inches (15.2 cm) behind the front mounting surface.

Studio Reference I: 60 pounds, 11 ounces (27.6 kg) net; 74 pounds, 3 ounces (33.7 kg) shipping weight.

Studio Reference II: 56 pounds, 2 ounces (25.5 kg) net; 69 pounds, 10 ounces (31.6 kg) shipping weight.

This page intentionally left blank

3 Voltage Conversion

The Studio Reference Amplifiers can be wired for 100 VAC, 120 VAC, 200 VAC, 220 VAC or 240 VAC operation. This is made possible by the use of a multitap transformer for the high energy power supplies. Perform the following procedure and refer to Figures 3.1 and 3.2 to convert the operating voltage. You may have to order the appropriate circuit breaker using the part number listed in Figure 3.2.

CAUTION: Because there is a risk of electric shock, only an experienced technician should attempt to alter the line voltage configuration.

1. Remove the top cover of the Studio Reference amplifier (held on by 8 screws).
2. With the front panel toward you, locate the control module (front center) and the tab connectors (upper

right hand corner of module).

3. Cut and remove the wire ties to access the jumpers and wires.
4. Refer to Figure 3.1 and make the appropriate changes for the desired operating voltage.
5. Install wire ties to dress the wires above the connections.
6. Note the 60 Hertz/50 Hertz switch on the left hand side of the module and change, if necessary, for the operating line frequency.
7. Refer to Figure 3.2 and change the Circuit Breaker if necessary.
8. On the rear of the unit, change the line cord tag to read the correct voltage. This is on the lower right hand side of the rear panel, just above the serial tag.
9. Reassemble the unit.

SPECIFIC VOLTAGE WIRING			
VOLTAGE	JUMPER	WP17 WHITE	WP16 BLACK
100V	P26—P14	P16	P17
120V	P26—P15	P16	P18
200V	P14—P16	P13	P17
220V	P15—P16	P13	P17
240V	P15—P16	P13	P18

Figure 3.1 Specific Voltage Wiring

CIRCUIT BREAKER SELECTION		
	100V, 120V	200V, 220V, 240V
REF 1	30 AMP, C 7756-7	20 AMP, C10193-8
REF 2	20 AMP, C10193-8	10 AMP, C10192-0

Figure 3.2 Circuit Breaker Selection

This page intentionally left blank

4 Circuit Theory

4.1 Overview

It should be noted that over time Crown makes improvements and changes to their products for various reasons. This manual is up to date as of the time of writing. For additional information regarding these amplifiers, refer to the applicable Technical Notes provided by Crown for this product.

This section of the manual explains the general operation of a Crown Studio Reference power amplifier. Topics covered include Front End, Grounded Bridge, ODEP and others. Due to variations in design from vintage to vintage (and similarities with other Crown products) the theory of operation remains simplified.

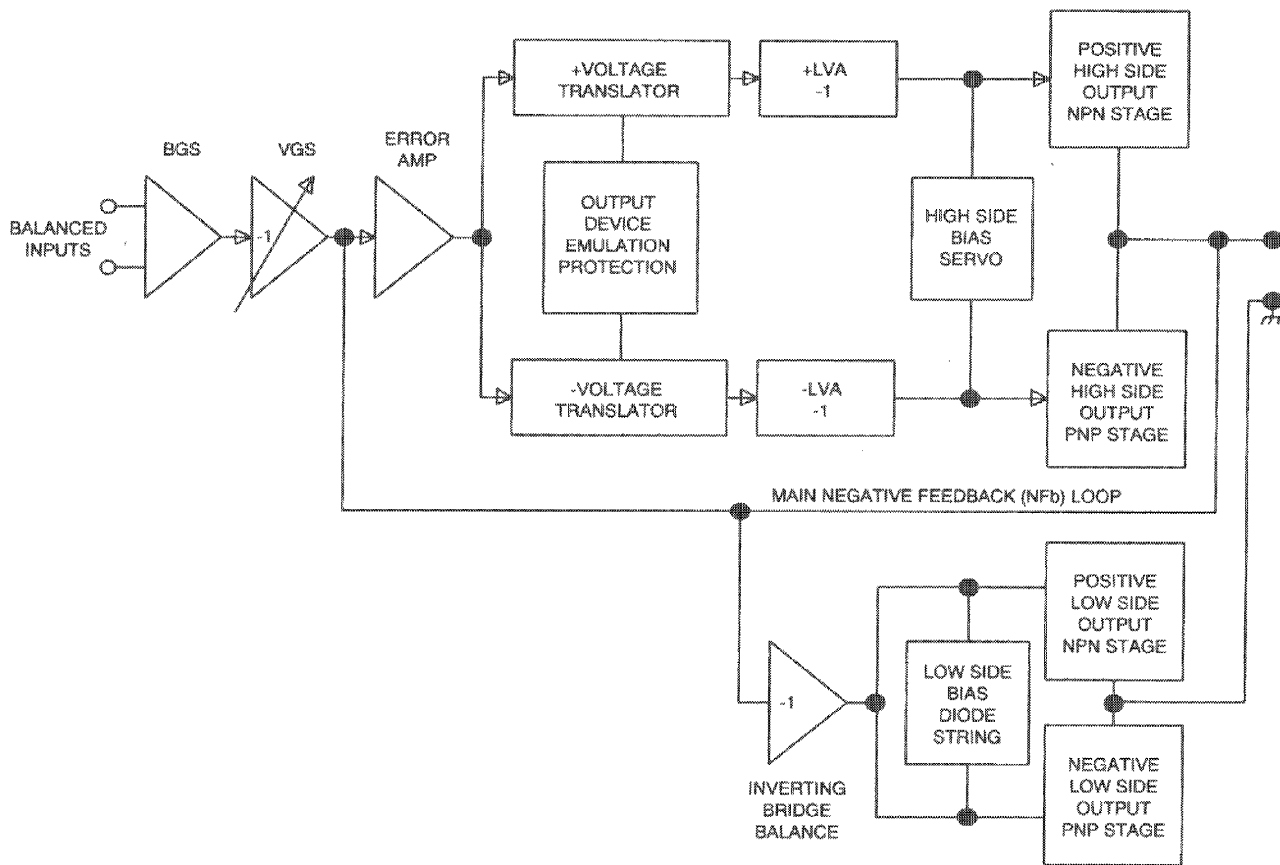

Figure 4.1 Simplified Studio Reference Block Diagram

4 Circuit Theory

4.2 Features

Studio Reference amplifiers utilize numerous Crown innovations, including grounded bridge and ODEP technologies. Cooling techniques make use of what is essentially air conditioner technology. Air flows bottom to top, and front to side. Air flows a short distance across a wide heatsink. This type of air flow provides significantly better cooling than the "wind tunnel" technology used by many other manufacturers. Output transistors are of the metal can type, rather than the plastic case style. This allows for a significantly higher thermal margin for the given voltage and current ratings. All devices used are tested and graded to ensure maximum reliability. Another electronic technique used is negative feedback. Almost all power amplifiers utilize negative feedback to control gain and provide stability, but Crown uses multiple nested feedback loops for maximum stability and greatly improved damping. Studio Reference amplifiers have damping in excess of 20,000 in the bass frequency range. This feedback, along with our compensation and ultra-low distortion output topology, make the Crown Studio Reference amplifier superior.

Features specific to the Studio Reference include: A high power toroidal transformer; Computer controlled, variable speed, whisper quiet fan; Built in AC power filter; Soft start circuit to control inrush current; Full overvoltage and internal fault protection. This amplifier can operate in either Bridged or Parallel Mono mode, as well as in Dual (stereo) mode. A sensitivity switch allows selection of input voltage required for rated output. Level controls are mounted on the front panel and are of the rotary type. Front panel indicators let the user know the status of amplifier enable, ODEP, signal presence (SPI), and distortion (IOC). Also included on the front panel is a five-segment display for each channel which displays either dynamic range in dB or output level in dB.

For additional details refer to the specification section, or to the applicable Reference Manual.

4.3 Front End Operation

The front end is comprised of three stages: Balanced Gain Stage (BGS), Variable Gain Stage (VGS), and the Error Amp. Figure 4.2 shows a simplified diagram of the front end and voltage amplification stages.

4.3.1 Balanced Gain Stage (BGS)

Input to the amplifier is balanced. The shield from the 1/4" inputs may be isolated from chassis ground by

an RC network to interrupt ground loops via the Ground Lift Switch. The non-inverting (hot) side of the balanced input is fed to the non-inverting input of the first op-amp stage. The inverting (negative) side of the balanced input is fed to the inverting input of the first op-amp stage. A potentiometer is provided for common mode rejection adjustment (R512). Electrically, the BGS is at unity gain. (From an audio perspective, however, this stage actually provides +6dB gain if a fully balanced signal is placed on its input.) The BGS is a non-inverting stage. Its output is delivered to the Variable Gain Stage.

4.3.2 Variable Gain Stage (VGS)

From the output of the BGS, the signal goes to the VGS, where gain is determined by the position of the Sensitivity Switch, and level is determined by the level control. VGS is an inverting stage with the input being fed to its op-amp stage. Because gain after this stage is fixed at 26 dB (factor of 20), greater amplifier sensitivity is achieved by controlling the ratio of feedback to input resistance. The Sensitivity Switch sets the input impedance to this stage and varies the gain such that the overall amplifier gain is 26 dB, or is adjusted appropriately for 0.775V or 1.4V input to attain rated output.

4.3.3 Error Amp

The inverted output from the VGS is fed to the non-inverting input of the Error Amp op-amp stage through an AC coupling capacitor (C100) and input resistor (R101). Amplifier output is fed back via the negative feedback (NFB) loop resistor (R103). The ratio of feedback resistor to input resistor fixes gain from the Error Amp input to the output of the amplifier at 26 dB. Diodes (D108, D122) prevent overdriving the Error Amp. Because the Error Amp amplifies the difference between input and output signals, any difference in the two waveforms will produce a near open loop gain condition which, in turn, results in high peak output voltage. The output of the Error Amp, called the Error Signal (ES) drives the Voltage Translators.

4.4 Voltage Amplification

The Voltage Translator stage separates the output of the Error Amp into balanced positive and negative drive voltages for the Last Voltage Amplifiers (LVAs), translating the signal from ground referenced $\pm 15V$ to $\pm V_{CC}$ reference. LVAs provide the main voltage amplification and drive the High Side output stages. Because there is a slight loss of gain in the translator stage, the gain after the translator is a factor of 25.2.

4 Circuit Theory

4.4.1 Voltage Translators

A voltage divider network splits the Error Signal (ES) into positive and negative drive signals for the balanced voltage translator stage. These offset reference voltages drive the input to the Voltage Translator transistors (Q101, Q102). A nested NFB loop from the output of the amplifier mixes with the inverted signal riding on the offset references. This negative feedback fixes gain and adds stability in the gain stages. The Voltage Translators are arranged in a common base configuration for a non-inverting signal with equal gain. They shift the audio from the $\pm 15V$ reference to VCC reference. Their outputs drive their respective LVA.

Also tied into the Voltage Translator inputs are ODEP limiting transistors (Q100, Q103) which also act as muting transistors. The ODEP transistors steal drive as dictated by the ODEP circuitry or shunt the audio as dictated by the fault circuit.

4.4.2 Last Voltage Amplifiers (LVAs)

The Voltage Translator stage channels the signal to the Last Voltage Amplifiers (LVAs) in a balanced configuration. The +LVAs (Q105/104) and -LVAs (Q110/111), with their push-pull effect through the Bias Servo, drive the fully complementary output stage. The LVAs are configured as common emitter amplifiers. This configuration provides sufficient voltage gain and inverts the audio. The polarity inversion is necessary to avoid an overall polarity inversion from input jack to output jack, and it allows the NFB loop to control Error Amp gain by feeding back to its non-inverting input (with its polarity opposite to the output of the VGS). With the added voltage swing provided by the LVAs, the signal then gains current amplification through the Darlington emitter-follower output stage.

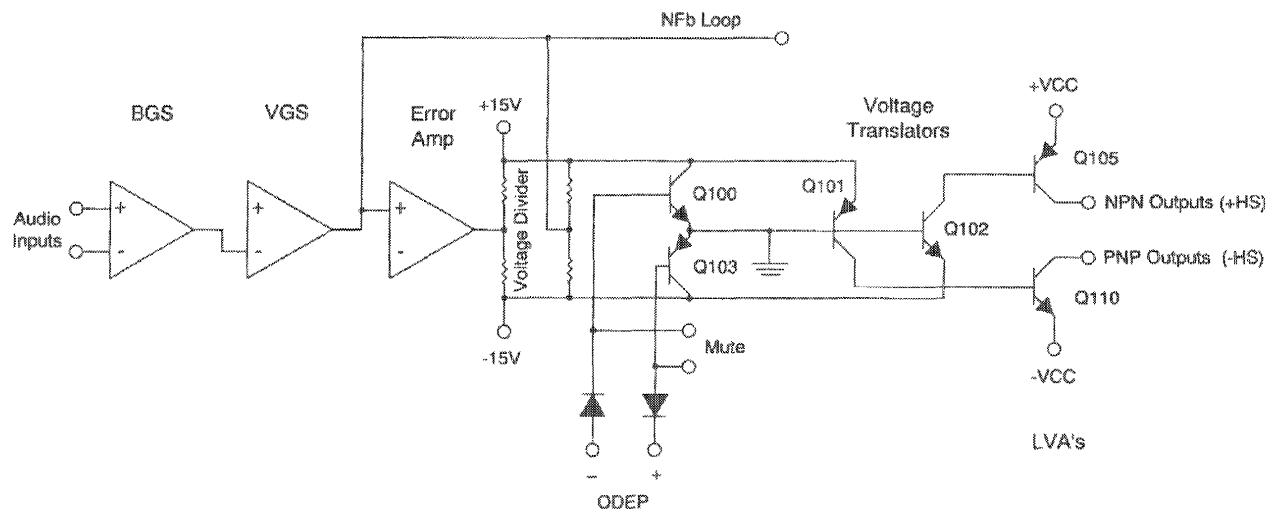

Figure 4.2 Simplified Amplifier Front End and Voltage Amplification Stages

4 Circuit Theory

4.5 Grounded Bridge Topology

Figure 4.3 is a simplified example of the grounded bridge output topology. It consists of four quadrants of three deep Darlington (composite) emitter-follower stages per channel: one NPN and one PNP on the High Side of the bridge (driving the load), and one NPN and one PNP on the Low Side of the bridge (controlling the ground reference for the rails). The output stages are biased to operate class AB+B for ultra low distortion in the signal zero-crossing region and high efficiency.

4.5.1 High Side (HS)

The High Side (HS) of the bridge operates much like a conventional bipolar push-pull output configuration. As the input drive voltage becomes more positive, the HS NPN conducts and delivers positive voltage to the load. Eventually the NPN devices reach full conduction and $+V_{cc}$ is across the load. At this time the HS PNP is biased off. When the drive signal is negative going, the HS PNP conducts to deliver $-V_{cc}$ to the load and the HS NPN stage is off.

The output of the +LVA drives the base of the predriver device. Together, the predriver and driver form the first two parts of the three-deep Darlington and are biased class AB. They provide output drive through the bias resistor, bypassing the output devices, at levels below about 100mW. An RLC network between the predriver and driver provide phase shift compensation and limit driver base current to safe levels. Output devices are biased class B, just below cutoff. At about 100mW output they switch on to conduct high current to the load. Together with predriver and driver, the output device provides an overall class AB+B output.

The negative half of the HS is almost identical to the positive half, except that the devices are PNP. One difference is that the PNP bias resistor is slightly greater in value so that PNP output devices run closer to the cutoff level under static (no signal) conditions. This is because PNP devices require greater drive current.

HS bias is regulated by Q18, the Bias Servo. Q18 is a V_{be} multiplier which maintains approximately 3.2V V_{ce} under static conditions. The positive and negative halves of the HS output are in parallel with this 3.2V. With a full base-emitter on voltage drop across predrivers and drivers, the balance of voltage results in approximately .3V drop across the bias resistors in the positive half, and about .5V across the bias resistor in the negative half. Q18 conduction (and thus bias)

is adjustable.

A diode string prevents excessive charge build up within the high conduction output devices when off. Flyback diodes shunt back-EMF pulses from reactive loads to the power supply to protect output devices from dangerous reverse voltage levels. An output terminating circuit blocks RF on output lines from entering the amplifier through its output connectors.

4.5.2 Low Side (LS)

The Low Side (LS) operates quite differently. The power supply bridge rectifier is not ground referenced, nor is the secondary of the main transformer. In other words, the high voltage power supply floats with respect to ground, but $\pm V_{cc}$ remain constant with respect to each other. This allows the power supply to deliver $+V_{cc}$ and $-V_{cc}$ from the same bridge rectifier and filter as a total difference in potential, regardless of their voltages with respect to ground. The LS uses inverted feedback from the HS output to control the ground reference for the rails ($\pm V_{cc}$). Both LS quadrants are arranged in a three-deep Darlington and are biased AB+B in the same manner as the HS.

When the amplifier output swings positive, the audio is fed to an op-amp stage where it is inverted. This inverted signal is delivered directly to the bases of the positive (NPN) and negative (PNP) LS predrivers. The negative drive forces the LS PNP devices on (NPN off). As the PNP devices conduct, V_{ce} of the PNP Darlington drops. With LS device emitters tied to ground, $-V_{cc}$ is pulled toward ground reference. Since the power supply is not ground referenced (and the total voltage from $+V_{cc}$ to $-V_{cc}$ is constant) $+V_{cc}$ is forced higher above ground potential. This continues until, at the positive amplifier output peak, $-V_{cc} = 0V$ and $+V_{cc}$ equals the total power supply potential with a positive polarity. In the Reference 1, for example, the power supply produces a total of 144V from rail to rail ($\pm 72V_{DC}$ measured from ground with no signal), therefore, the amplifier output can reach a positive peak of +144V.

Conversely, during a negative swing of the HS output where HS PNP devices conduct, the op-amp would output a positive voltage forcing LS NPN devices to conduct. This would result in $+V_{cc}$ swinging toward ground potential and $-V_{cc}$ swinging further from ground potential. At the negative amplifier output peak, $+V_{cc} = 0V$ and $-V_{cc}$ equals the total power supply potential with a negative polarity. Using the same ex-

4 Circuit Theory

ample as above, a 144V supply would allow a negative output peak of -144V. In summary, a power supply which produces a total of 144VDC rail to rail (or ± 72 VDC statically) is capable of producing 288V peak-to-peak at the amplifier output when the grounded bridge topology is used.

The total effect is to deliver a peak to peak voltage to the speaker load which is twice the voltage produced by the power supply. Benefits include full utilization of the power supply (it conducts current during both halves of the output signal; conventional designs require two power supplies per channel, one positive and one negative), and never exposing any output device to more than half of the peak to peak output voltage (which does occur in conventional designs).

Low side bias is established by the same method as high side bias. Q00 is the bias transistor. Bias is adjustable via potentiometer. Flyback diodes perform the same function as the HS flybacks. The output of the LS is tied directly to chassis ground via ground strap.

4.6 Output Device Emulation Protection (ODEP)

To further protect the output stages, a specially developed ODEP circuit is used. It produces a complex analog output signal. This signal is proportional to the always changing safe-operating-area margin of the

output transistors. The ODEP signal controls the Voltage Translator stage by removing drive that may exceed the safe-operating-area of the output stage.

ODEP senses output current by measuring the voltage dropped across LS emitter resistors. LS NPN current (negative amplifier output) and +Vcc are sensed, then multiplied to obtain a signal proportional to output power. Positive and negative ODEP voltages are adjustable via two potentiometers. Across \pm ODEP are a PTC and a thermal sense (current source). The PTC is essentially a cutoff switch that causes hard ODEP limiting if heatsink temperature exceeds a safe maximum, regardless of signal level. The thermal sense device causes the differential between +ODEP and -ODEP to decrease as heatsink temperature increases. An increase in positive output signal into a load will result in -ODEP voltage dropping; an increase in negative output voltage and current will cause +ODEP voltage to drop. A complex RC network between the \pm ODEP circuitry is used to simulate the thermal barriers between the interior of the output device die (immeasurable by normal means) and the time delay from heat generation at the die until heat dissipates to the thermal sensor. The combined effects of thermal history and instantaneous dynamic power level result in an accurate simulation of the actual thermal condition of the output transistors.

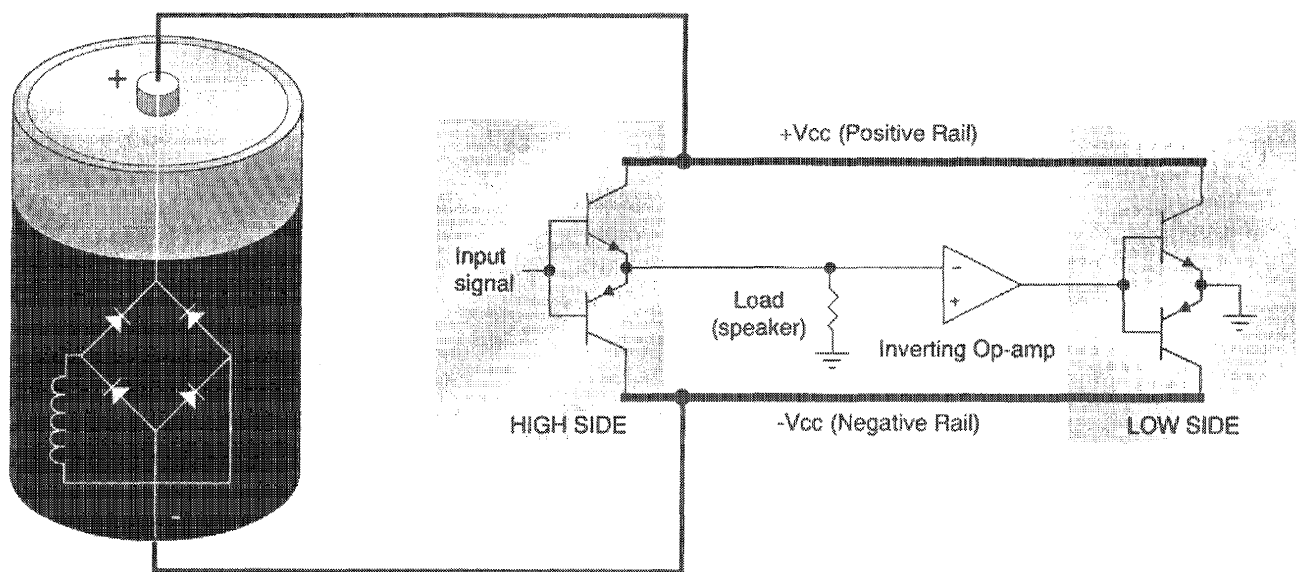

Figure 4.3 Simplified Grounded Bridge

4 Circuit Theory

4.7 Control Circuitry

The Reference amplifiers have fault protect circuitry to guard against dangerous DC voltages and turn on/off transients. At the heart of this circuitry is the window comparator U102. The fan control circuit monitors the thermal conditions, via the ODEP circuit, and regulates the fan speed accordingly.

4.7.1 DC/LF Protect

The amplifier output signal is passed through a low pass filter (R184, C119, R186 and C107) to the window comparator (U102). If the DC component exceeds a predetermined level, the output of the comparator (pins 1 and 2) goes low. The result is U102 pin 13 going to a high state which turns on the muting transistors and disables the high energy supply by opening the relay K2.

4.7.2 Fault Circuit

The fault circuitry is designed to mute the audio and disable the high energy supply in the event of an output fault. A *fault* is defined as any time in which the output semiconductors, in both the negative and positive sections, draw excessive currents.

The low side of bridge fault detection consists of Q128, Q129 and Q130. If both NPN and PNP output devices are conducting excessive currents, the output of U102 (pin 13) is forced high. This disables the high energy supply and mutes the audio path.

The high side of bridge fault detection consists of Q126, Q127 and U101. This circuit compares the NPN and PNP drive to the feedback signal, giving a representation of output device current. If excessive current occurs, the window comparator U102 is triggered through the opto isolator U101.

4.7.3 Turn On Delay

During power up, the capacitor C110 is charging, which causes the non-inverting input (pin 10) of U102 to be low and the output (pin 13) to be high. With pin 13 high, the high energy rails are disabled by the relay K2, and the audio is muted by the muting transistors. After approximately 4 seconds, C110 is fully charged and pin 10 is pulled high, thus causing pin 13 to go low and the amplifier to come out of standby.

4.7.4 Fan Control

The *Fan Control Signal* is taken from the positive ODEP bias voltages. Both channel 1 and channel 2 ODEP voltages are combined to create the fan control sig-

nal. As the output transistor/heatsink increases in temperature, the ODEP voltage level will drop from +10VDC to near 0VDC. If there is a drop in one or both ODEP voltages it will cause the fan control signal to change. The fan control signal starts out around -12.5VDC, and after complete ODEP limiting, ends up at +12.5VDC. This voltage is fed into the inverting input of the op-amp U1B. The initial output of U1B is high (+24V), and as the fan control signal becomes more positive, this output will become low, thus turning on the fan accordingly. The output of U1B drives U4, an opto-triac, which in turn drives Q4, a triac in the AC supply for the fan.

The *Gating Signal* is fed into the non-inverting input of the op-amp U1B. This gating signal is a product of U1A, Q3, and the *Fan Enable* signal from the display module. C12 and R19 form an RC timing circuit that, from the +15V supply, begins to charge. U1A monitors the line voltage wave form and is a 0V crossing detector. Every time the line waveform crosses 0V, Q3 is turned on and discharges C12. This causes a ramping type waveform. The higher positive portion of the waveform is used to turn off the opto-triac, even when the fan control signal itself is of a value to turn on the fan. Therefore, the fan control current has a duty cycle.

The *Fan Enable* signal comes from the display module and holds the *Gating Signal* high when the amplifier is in standby. Therefore the fan will not turn when the amplifier is in standby.

4.8 Power Supply

At the heart of the power supply is a multi-tap toroidal power transformer. There are two ungrounded, high energy, secondary windings, one for each channel, and there is one low voltage winding for the 24V supplies. There is also a thermal cut off switch built into the transformer which will disable the secondary windings in the event of the transformer overheating.

4.8.1 AC Line Filter

D24 and D25 are in the AC primary. They are wired such that they null out any DC component in the AC power. This is done because the toroidal transformer may develop a mechanical buzz if there is any DC shift in the AC waveform applied to the transformer primary.

4.8.2 Soft Start

Due to the high inrush current that is possible with the toroidal transformer, a *Soft Start Circuit* has been in-

4 Circuit Theory

incorporated into the amplifier. This circuit allows the transformer to be energized before full power is applied to it. When power is first applied to the amplifier, K1 is open, and power is applied to the transformer through the PTC R1. As current is drawn through R1 it heats up and the resistance lowers. This allows the power to the transformer to ramp up. When the 24V supply is enough to energize the relay K1, it closes and power is applied directly to the transformer.

4.8.3 Over Voltage Protection

U1D serves as a window comparator for the purpose of over line voltage control. In the event that the line voltage exceeds 10% over the rated line voltage, the high energy power supplies are disabled. R7 supplies the regulated +15V to pin 10 of U1D and serves as the window reference level. With pin 10 in control of U1D, the output (pin 13) has a logic low which is applied across D13 and D14. This prevents conduction and allows Q1 to remain on, which thus allows K2 to remain energized.

Resistors R3, R4, R5 and R6 serve as a resistor dropping network from the unregulated +24V supply to ground. As the line voltage increases, the unregulated supply will increase. The voltage level on the wiper of R4 is applied to Pin 11 (non-inverting input). When the level exceeds the window level of pin 10, the circuit switches states. This allows D13 and D14 to conduct, placing a logic high on the base of Q1. This, in turn, biases off Q1 and de-energizes K2.

4.9 Display Circuitry

4.9.1 IOC

U3A and U3B serve as a voltage comparator with R13, R15 and R17 as the resistor dropping network. Pin 7 has a window level of +7V and pin 4 has a window of -7V. U3A and U3B have a logic high which turns off Q1 and the IOC LED E1. When the error signal from the error amp appears, the 7V window is overcome and switches the state of U3A and U3B. Q1 is then biased on and the IOC LED, E1, illuminates. The capacitor C27 makes sure the LED is lit long enough for the human eye to see it.

4.9.2 ODEP

U1D on the display module is the current source for the ODEP LED E15. Under normal operating conditions pin 14 of U1D is a negative voltage. This allows D7 to conduct and E15 to illuminate. As the ODEP signal drops to the point where ODEP limiting takes

place, Pin 14 becomes less negative and the LED begins to fade.

U5C is a comparator and switches its output high when the channel is in standby. This keeps D7 from conducting and the LED from illuminating when the channel is in standby.

4.9.3 Signal Indication

Incorporated on the display module are three modes of signal indication.

SPI (Signal Presence Indication)

U1A and D3 serve to rectify the amplifier output signal. U1B takes this rectified signal and drives the LED, E3, which illuminates any time there is signal present at the output of the amplifier channel.

Dynamic Range

With the switch S1 in the Dynamic position, this rectified audio signal is placed on the inverting inputs of a sequence of window comparators. This signal is rectified but unfiltered, therefore it contains the peak value of the audio waveform. U3C, U3D, U5A, U5B and U5D serve as the current sources for the five Dynamic Range LEDs. R29, R31, R33, R35, R37 and R39 provide a resistor dropping network for the inverting inputs to the LED drivers.

This same rectified signal is placed on the non-inverting inputs via the filtering function of C3 and the op-amp, U1C. This filtered signal is of an RMS value. With the non-inverting inputs receiving the RMS value, and the inverting inputs receiving the peak value, the output of each LED comparator equals the dynamic range of the signal.

Output Level

With the switch, S1, in the Level position, the peak signal is still placed on the inverting inputs of the comparator drivers. A small DC level is placed on all of the non-inverting inputs. This DC level serves as a calibrated reference for comparators. R78 calibrates the display balance between the two channels of the amplifier.

This page intentionally left blank

5 Electrical Checkout and Adjustment Procedures

5.1 General Information

The following test procedures are to be used to verify operation of this amplifier. DO NOT connect a load or inject a signal unless directed to do so by the procedure. These tests, though meant for verification and alignment of the amplifier, may also be very helpful in troubleshooting. For best results, tests should be performed in order.

All tests assume that AC power is from a regulated 120 VAC source. Test equipment includes an oscilloscope, a DMM, a signal generator, loads, and I.M.D. and T.H.D. noise test equipment.

5.2 Standard Initial Conditions

Level controls fully clockwise.

Stereo/Mono switch in Stereo.

Sensitivity switch in 26 dB fixed gain position.

It is assumed, in each step, that the conditions of the amplifier are per these initial conditions unless otherwise specified.

5.3 DC Offset

Spec: 0 VDC, ± 2 mV.

Initial Conditions: Controls per standard, inputs shorted.

Procedure: Measure DC voltage at the output connectors (rear panel). There is no adjustment for output offset. If spec is not met, there is an electrical malfunction. Slightly out of spec measurement is usually due to U104/U204 out of tolerance.

5.4 Output Bias Adjustment

Spec: 300 to 320 mVDC.

Initial Conditions: Controls per standard, heatsink temperature less than 40°C.

Procedure: Measure DC voltages on the output module across R02, adjust R26 if necessary. Measure DC voltages on the output module across R21, adjust R23 if necessary. Repeat for second channel.

5.5 ODEP Voltage Adjustment

Spec: Bias Per Chart, ± 0.1 V DC.

Initial Conditions: Controls per standard, heatsink at room temperature 20 to 30°C (68 to 86°F). Note: This adjustment should normally be performed within 2 minutes of turn on from ambient (cold) conditions. If possible, measure heatsink temperature; if not, measure ambient room temperature. Use this information when referencing the following chart.

°F	°C	V _{-ODEP}	V _{+ODEP}
66	18.9	-10.31	10.31
68	20.0	-10.26	10.26
70	21.1	-10.20	10.20
72	22.2	-10.14	10.14
74	23.3	-10.09	10.09
76	24.4	-10.03	10.03
77	25.0	-10.00	10.00
78	25.6	-9.97	9.97
80	26.7	-9.91	9.91
82	27.8	-9.86	9.86
84	28.9	-9.80	9.80
86	30.0	-9.74	9.74
88	31.1	-9.69	9.69
90	32.2	-9.63	9.63
92	33.3	-9.57	9.57
94	34.4	-9.51	9.51

-ODEP Procedure: Measure pin 3 of J500 and, if necessary, adjust R121 to obtain V_{-ODEP} as specified above. Measure pin 3 of J700 and, if necessary, adjust R221 to obtain V_{-ODEP} as specified above.

+ODEP Procedure: Measure pin 4 of J500 and, if necessary, adjust R132 to obtain V_{+ODEP} as specified above. Measure pin 4 of J700 and, if necessary, adjust R232 to obtain V_{+ODEP} as specified above.

5.6 AC Power Draw

Spec: 70 Watts maximum quiescent.

Initial Conditions: Controls per standard.

Procedure: With no input signal and no load, measure AC line wattage draw. If current draw is excessive, check for high AC line voltage or high bias voltage.

5.7 High Line Cutout

Spec: Unit goes into standby when the AC line voltage goes 10% to 12% above nominal.

Initial Conditions: Controls per standard.

Procedure: No load, no signal. Bring up AC line voltage with a variac 10% to 12% high. For 120VAC units this is 132VAC to 134.4VAC. Unit should go into standby. Adjust R4 on the control module if necessary.

5.8 Common Mode Rejection

Spec: >70 dB at 1 kHz.

Initial Conditions: Controls per standard.

Procedure: No load. Inject a 0 dBu (.775VRMS), 1 kHz sine wave into each channel, one channel at a time, with inverting and non-inverting inputs shorted together. Adjust R512 (Ch1) and R612 (Ch2) for less than 4.9mVRMS (-44 dBu) at the amplifier output.

5 Electrical Checkout and Adjustment Procedures

5.9 Voltage Gain

Spec 26dB Gain: Gain of $20.0 \pm 3\%$.

Spec 0.775V Sensitivity: REF I —Gain of $100.65 \pm 3\%$.
REF II —Gain of $68.28 \pm 3\%$.

Spec 1.4V Sensitivity: REF I —Gain of $55.71 \pm 3\%$.
REF II —Gain of $37.80 \pm 3\%$.

Initial Conditions: Controls per standard.

26 dB Procedure: Inject a 0.775 VAC 1 kHz sine wave with the Sensitivity Switch in the 26 dB position. Measure 15.5 VAC ± 0.5 VAC at the amplifier output.

0.775V Procedure: Inject a 0.775 VAC 1 kHz sine wave with the Sensitivity Switch in the 0.775V position. REF I measure 78 VAC, ± 2.3 VAC, at the amplifier output. REF II measure 52.9 VAC, ± 1.6 VAC, at the amplifier output.

1.4V Procedure: Inject a 1.4 VAC 1 kHz sine wave with the Sensitivity Switch in the 1.4V position. REF I measure 78 VAC, ± 2.3 VAC, at the amplifier output. REF II measure 52.9 VAC, ± 1.6 VAC, at the amplifier output.

5.10 Level Controls

Spec: Level controlled by level controls.

Initial Conditions: Controls per standard.

Procedure: No Load. Inject a 1 kHz sine wave. With level controls fully clockwise you should see full gain. As controls are rotated counterclockwise, observe similar gain reduction in each channel. When complete, return level controls to fully clockwise position.

5.11 Current Limit

Spec: REF I —Current limit at 43 amps, ± 3 amps.

REF II —Current limit at 30 amps, ± 3 amps.

Initial Conditions: Controls per standard.

Procedure: Load each channel to 1 Ohm. Inject a 1 kHz differentiated (or 10% duty cycle) square wave. See Figure 5.1. Increase output level until current limiting occurs. Refer to Figure 5.2 for wave form.

REF I will limit (clip) at 43 volt peak, ± 3 volts.

REF II will limit (clip) at 30 volt peak, ± 3 volts.

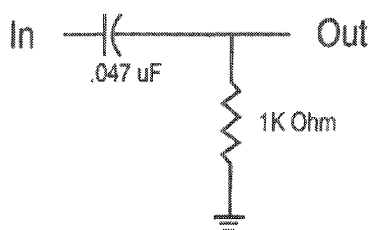

Figure 5.1 Differentiator Circuit

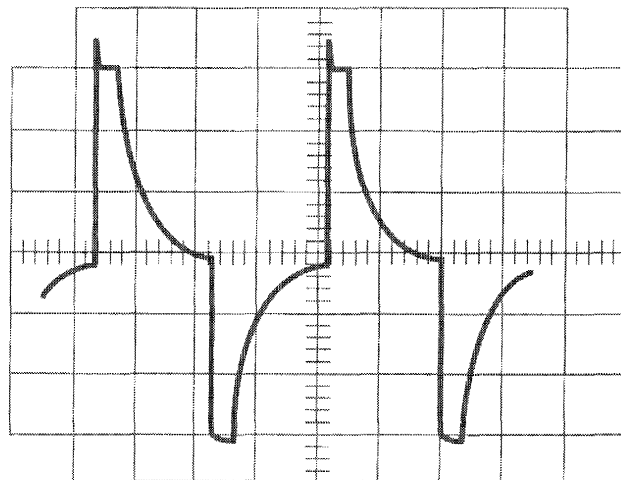

Figure 5.2 Differentiated Square Wave

5.12 Slew Rate & 10 kHz Square Wave

Spec: REF I — 23 ± 3 V/ μ S.

REF II — 19 ± 3 V/ μ S.

Initial Conditions: Controls per standard.

Procedure: Load each channel to 8 ohms. Inject a 10 kHz square wave at a level of 2 to 5 volts below clip. Observe the slope of the waveform and calculate the slew rate. Any ringing must die out in less than 1/4 of the period, and its amplitude must be less than 2% of the waveform amplitude. See Figure 5.3.

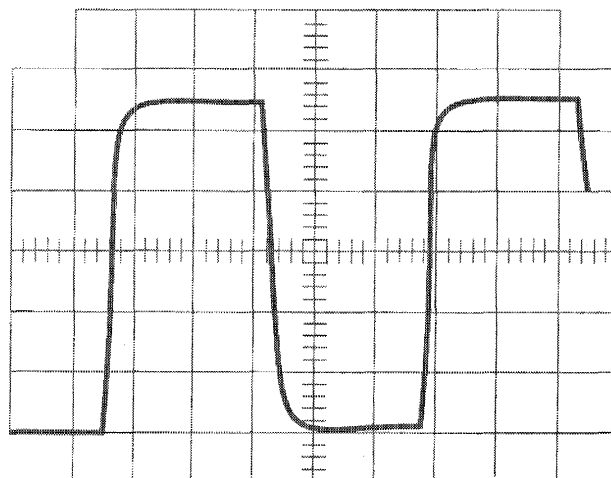

Figure 5.3 10 kHz Square Wave

5 Electrical Checkout and Adjustment Procedures

5.13 Crosstalk

Spec: -60dB at 20 kHz.

Initial Conditions: Controls per standard. Terminate input of channel not driven with 600 ohms.

Procedure: 8 ohm load on each channel. Inject a 20 kHz sine wave into the channel 1 input and increase output level to full power (REF I = 78 VAC, REF II = 52 VAC). For REF I measure less than 78 mVAC at the output of channel 2. For REF II measure less than 52 mVAC at the output of channel 2. Repeat by injecting the signal into channel 2 and measuring channel 1.

5.14 Output Power

For 120V 60Hz units:

Spec at 8 Ohm Stereo: REF I \geq 780W at 0.02% THD.
REF II \geq 355W at 0.02% THD.

Spec at 4 Ohm Stereo: REF I \geq 1160W at 0.02% THD.
REF II \geq 555W at 0.02% THD.

For international 50Hz units:

Spec at 8 Ohm Stereo: REF I \geq 750W at 0.1% THD.
REF II \geq 355W at 0.1% THD.

Spec at 4 Ohm Stereo: REF I \geq 1095W at 0.1% THD.
REF II \geq 535W at 0.1% THD.

Initial Conditions: Controls per standard.

Procedure: Load each channel to 8 ohms. Inject a 1 kHz sine wave and measure output power, at specified THD, with both channels driven.

Next, load each channel to 4 ohms. Inject a 1 kHz sine wave and measure output power, at specified THD, with both channels driven.

5.15 Reactive Loads

Spec: No oscillations. Safe with all types of loads.

Initial Conditions: Controls per standard.

Procedure Capacitive: Load each channel to 8 ohms in parallel with 2 μ F. Inject a 20 kHz sine wave. REF I output level = 45 VAC, REF II output level = 30 VAC. Drive load for 10 seconds. No oscillations.

Procedure Inductive: Load each channel to 8 ohms in parallel with 159 μ Henries. Inject a 1 kHz sine wave. REF I output level = 36 VAC. REF II output level = 28 VAC. See Figures 5.4 and 5.5 for typical waveform shapes. Test duration is 5 seconds.

Procedure Torture: Load each channel with the primary (red and black leads) of a PSU transformer (D 7040-5). Inject a 20 Hz sine wave into each channel. REF I output level = 40 VAC. REF II output level = 37.5 VAC. Observe 3 to 7 flyback pulses in both polarities. Test duration is 10 seconds. See Figure 5.6 for typical waveform shape.

Procedure Short: Inject a 60 Hz sine wave. REF I output level = 40 VAC. REF II output level = 28 VAC. After establishing signal, short the output for 10 seconds.

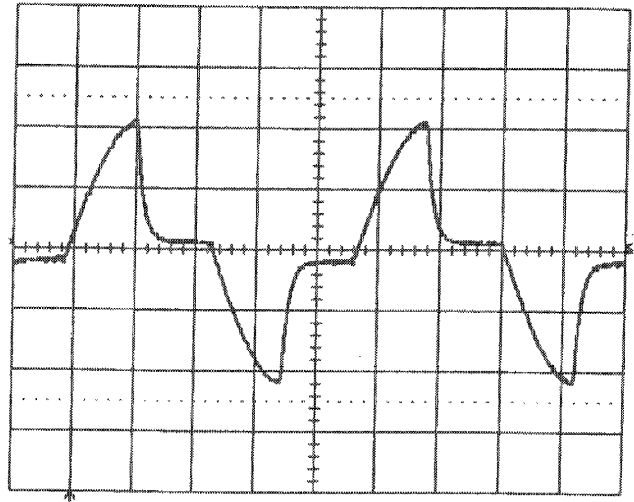

Figure 5.4 Inductive Load Cold

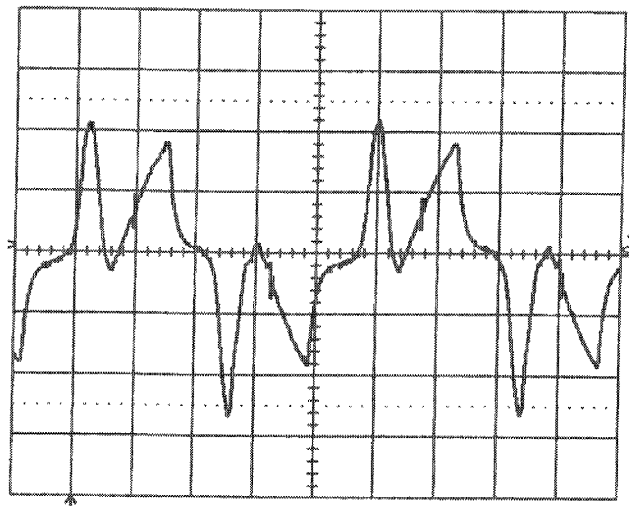

Figure 5.5 Inductive Load Warm

5 Electrical Checkout and Adjustment Procedures

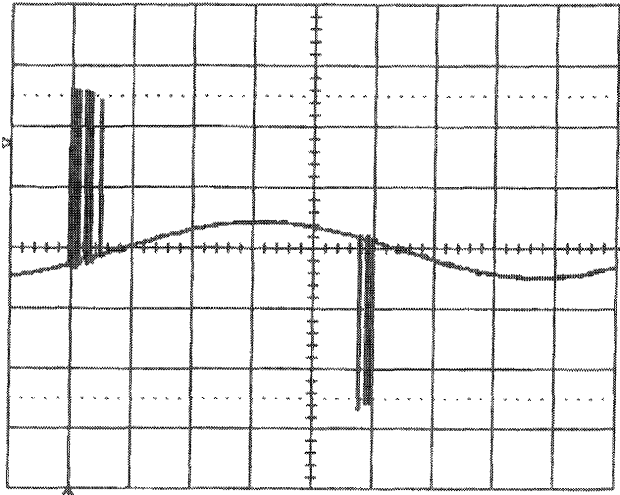

Figure 5.6 Torture Test Waveform

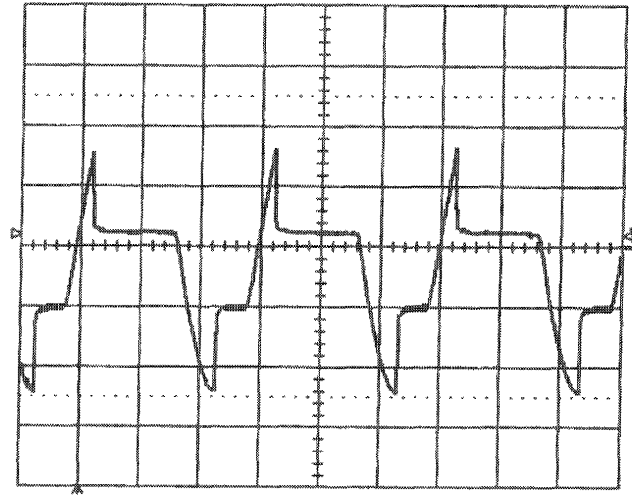

Figure 5.7 ODEP Limiting Waveform

5.16 ODEP Limiting

Spec: No oscillation on ODEP Limiting wave form. ODEP LED dims and is out as the amplifier starts ODEP limiting. Either channel controls limiting in Parallel Mono Mode.

Initial Conditions: Controls per standard; rag or other obstruction blocking fan so that it does not turn.

Procedure: Load the amplifier to 4 ohms on each channel. Inject a sine wave with the same frequency as the AC power line. REF I output level = 40 VAC. REF II output level = 28 VAC. After a few minutes observe a wave form similar to Figure 5.7. Remove the input signal from both channels and allow the amplifier to cool for a few minutes. Switch the amplifier to Parallel Mono and remove the load from channel 1. Inject the signal into channel 1 and observe that ODEP limiting occurs at the output of both channels. Remove the load from channel 2, and install the load on channel 1. Again, observe that both channels limit. Return all amplifier controls to standard initial conditions. Remove the fan obstruction.

5.17 Mute and Turn On Delay

Spec: Clamps signal; 3 to 5 second turn on delay.

Initial Conditions: Controls per standard.

Procedure: No load. Inject a 1 kHz sine wave into both channels. Observe the output signal with an oscilloscope. Turn the amplifier off with the front panel switch. The amplifier should clamp the signal, not allow it to decay with the power supplies. Turn the amplifier back on and observe the 3 to 5 second delay before it comes back out of standby. Note that both channels may not come out of standby at the exact same time.

5.18 Low Frequency Protection

Spec: Amplifier mutes for low frequency.

Initial Conditions: Controls per standard.

Procedure: No load. Inject a 0.5 Hz 12 volt peak-to-peak square wave, or a 1 Hz 17 V peak-to-peak sine wave into each channel, one channel at a time, and verify that the channel driven cycles into standby. Once in standby, it will try to cycle out of standby every 3 to 5 seconds.

5 Electrical Checkout and Adjustment Procedures

5.19 Signal to Noise Ratio

Spec: REF I 120 dB, A weighted.

REF II 117 dB, A weighted.

Initial Conditions: Controls per standard. Short inputs.

Procedure: Load each channel to 8 ohms. For REF I measure less than 78 μ V at the output of each channel. For REF II measure less than 74 μ V at the output of each channel.

5.20 Intermodulation Distortion

Spec at 0 dB Output (Full Power): 0.005%.

Spec at -35 dB Output: 0.02%.

Initial Conditions: Controls per standard.

Procedure: Load each channel to 8 ohms. Inject a SMPTE standard IM signal (60 Hz and 7 kHz sine wave mixed at 4:1 ratio). For REF I set the 60 Hz portion of the sine wave for 62 volts RMS output. For REF II set the 60 Hz portion of the sine wave for 41 volts RMS output. Set the 7 kHz portion to 25%. With an IM analyzer measure less than 0.005% IMD. Repeat test at -35 dB and measure less than 0.02% IMD.

5.21 LED Functions

Enable LED: On when power is applied and front panel switch is engaged.

Signal LED: On with signal at output of amplifier.

IOC LED: On when THD reaches approximately 0.05%.

ODEP LED: Dims and goes out as the amplifier starts to ODEP limit.

5.22 Display Set-Up

Spec: Ladder displays balance each other; Indicators illuminate at output voltages per chart below.

Initial Conditions: Controls per standard. Meter Mode Switch in the Output Level position.

Procedure: With the display set to read output level inject a 1 kHz sine wave into both channels of the amplifier. Adjust the level so that the -10 dB LEDs pulse on and off. Adjust R78 on the display board until the Ch 1 and Ch 2 -10 dB LEDs pulse at the same frequency.

Note: The complete front panel needs to be disassembled in order to access the display board.

Next, verify that each indicator illuminates per the chart below.

<u>Level Indicator</u>	<u>Output Voltage</u>
-20 dB	6.95 - 8.75 VAC
-15 dB	12.36 - 15.56 VAC
-10 dB	21.90 - 27.67 VAC
-5 dB	39.09 - 49.21 VAC
0 dB	69.51 - 87.51 VAC

5.23 Turn On Transients

Spec: No dangerous transients.

Initial Conditions: Controls per standard.

Procedure: From an off condition, turn on the amplifier and monitor the output noise at the time of turn on.

Note: Turn on noise may increase significantly if the amplifier is cycled off and on.

5.24 Turn Off Transients

Spec: No dangerous transients.

Initial Conditions: Controls per standard.

Procedure: From an on condition, turn off the amplifier and monitor the output noise at the time of turn off.

Note: Turn off noise may increase significantly if the amplifier is cycled off and on.

5.25 Post Testing

After completion of testing, if all tests are satisfactory, the amplifier controls should be returned to the positions required by customer. If conditions are unknown or unspecified, factory settings are as follows:

Level Controls: 9 to 11 O'Clock.

Sensitivity Switch: 0.775V U.S., 1.4V International.

Stereo/Mono Switch: Stereo.

Meter Switch: On.

Meter Mode Switch: Dynamic.

Ground Lift: Lift.

Power: Off.

This page intentionally left blank

6 Schematics

This page intentionally left blank

7 Parts Information

7.1 General Information

This chapter contains illustrations and parts lists for the Studio Reference amplifiers. The parts lists in this chapter are for all mechanical parts and parts not included on a module (circuit board). Chapter 8 contains artwork and parts lists for all modules.

7.2 Standard and Special Parts

Many smaller electrical and electronic parts used in the Studio Reference amplifiers are stocked by, and available from, electronic supply houses. However, some electronic parts that appear to be standard are actually special. A part ordered from Crown will assure an acceptable replacement. Structural items such as covers and panels are available only from Crown.

7.3 Ordering Parts

When ordering parts, be sure to give the amplifier model and serial number and include a description and Crown Part Number (CPN) from the parts listing. Price quotes are available on request.

7.4 Shipment

Shipment will be normally made by UPS or best other method unless you specify otherwise. Shipments are made to and from Elkhart, IN, only. Established accounts with Crown will receive shipment freight pre-paid and will be billed. All others will receive shipment on a C.O.D. or pre-payment (check or credit card) basis.

7.5 Terms

Normal terms are pre-paid. Net-30 days applies to only those firms having pre-established accounts with Crown. If pre-paying, the order must be packed and weighed before a total bill can be established, after which an amount due will be issued and shipment made upon receipt of pre-payment. New parts returned for credit are subject to a 10% re-stocking fee, authorization from the Crown Parts Department must be obtained before returning parts for credit.

The Crown Parts Department is not a general parts warehouse. Parts sold by Crown are solely for servicing Crown products.

Part prices and availability are subject to change without notice.

7.6 Illustrated Parts Lists

Contained within this section are the illustrated parts lists for the Studio Reference I and II amplifiers. The electrical and electronic parts in the assembly drawings are referred to by Crown Part Number (CPN), and quantities used are indicated. Those parts are also shown in the circuit schematics (chapter 6), and are identified there by circuit designation.

Crown Parts Department

Mailing Address:

PO Box 1000
Elkhart, IN USA 46515-1000

Shipping Address:

Plant 2 S.W.
1718 W. Mishawaka Rd.
Elkhart, IN USA 46517

Phone: (219) 294-8200
Toll Free: (800) 342-6939
FAX: (219) 294-8124

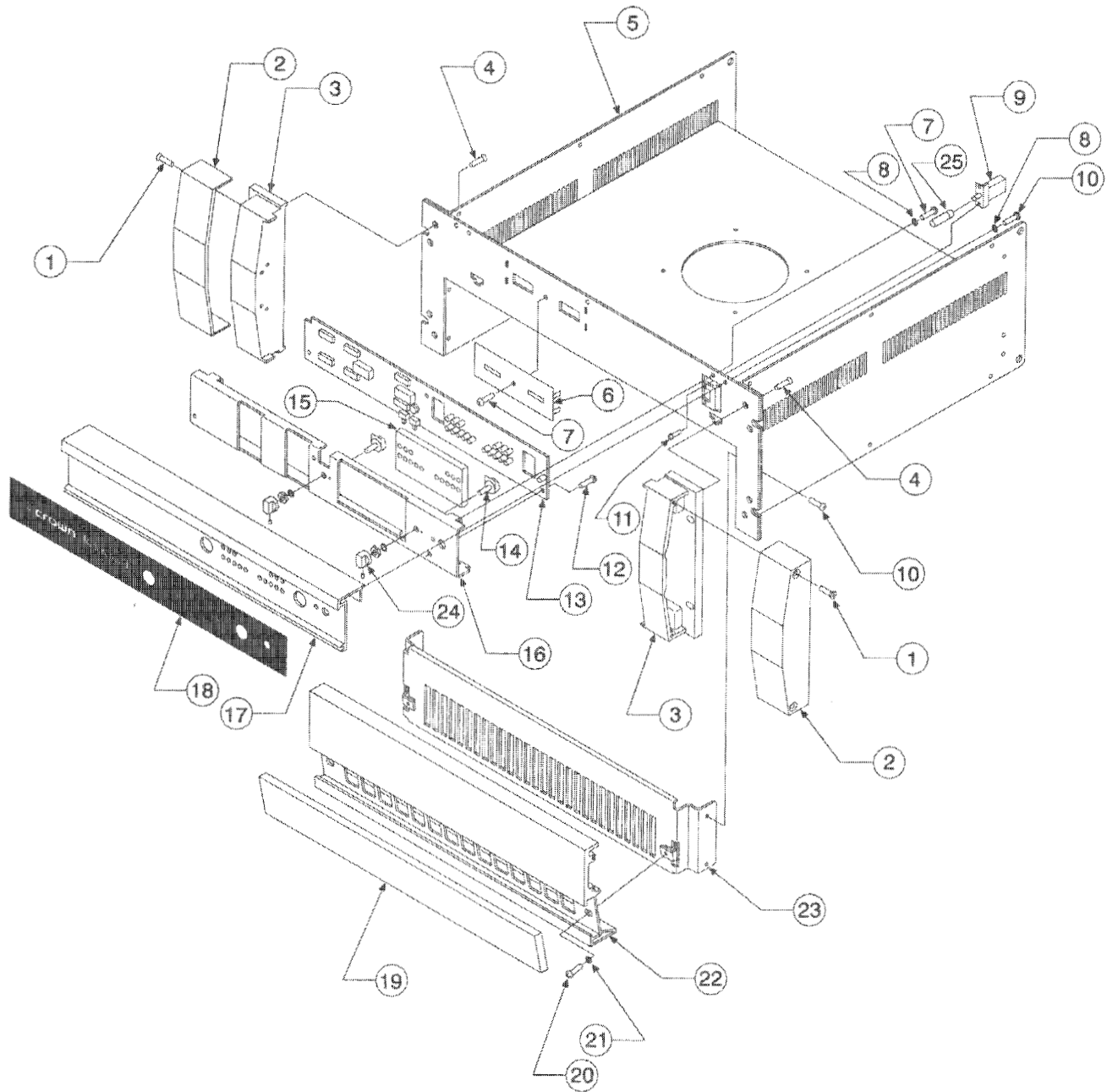

Figure 7.1 Front Panel Parts

Front Panel Parts

See Figure 7.1

Item #	Description	Part # (CPN)	Qty.	Notes
1	Screw, 8-32 x .75 FLTHD	A10091-70812	4	End Cap
2	End Cap	101101-1	2	
3	Handle	101102-1	2	
4	Screw, 8-32 x 0.5 FLTHD	A10091-70808	4	Handles
5	Main Chassis	F12875-5	1	
6	Holder, Cable Fishpaper	F11564-6	1	
7	Screw, 6-32 x .312 PNHD T15	C9491-9	3	Display Brkt
8	#8 Star Washer	A10094-5	2	
9	DPDT On/Off Push Button Switch	C10181-3	1	
10	Screw, 6-32 x 3/8 PNHD Tri	C104510	24	Covers, etc.
11	Screw, 4-40 x .375	C5961-5	2	On/Off Switch
12	Screw, 6-32 x .3125	A10086-10605	3	Display
13	Display Module, REF I	Q43018-3	1	
	Display Module, REF II	Q43312-0	1	
14	Pot, 5K ohm Linear 31 Det.	C8401-9	2	
15	Isolator, LED Foam	F11787-3	1	
16	Display Bracket	M21435-9	1	
17	Front Panel, Top Extrusion	101100-1	1	
18	Overlay, REF I	D 8669-0	1	
	Overlay, REF II	D 8647-6	1	
19	Air Filter	D 8763-1	1	
20	Screw, 8-32 x .37 RDHD	A10086-70806	2	Btm Extrusion
21	#8 Star Washer	A10094-5	2	
22	Front Panel, Bottom Extrusion	101099-1	1	
23	Finger Guard	F12876-3	1	Sub Front
24	Knob	D 8466J0	2	Level
	Set Screw, 6-32 x .18	C 6005-0	2	Level Knobs
Not Shown	Screw, 8-32 x .5 PNHD Taptite	A10110-70808	8	Handles
25	Push Button	D 8221J9	1	On/Off

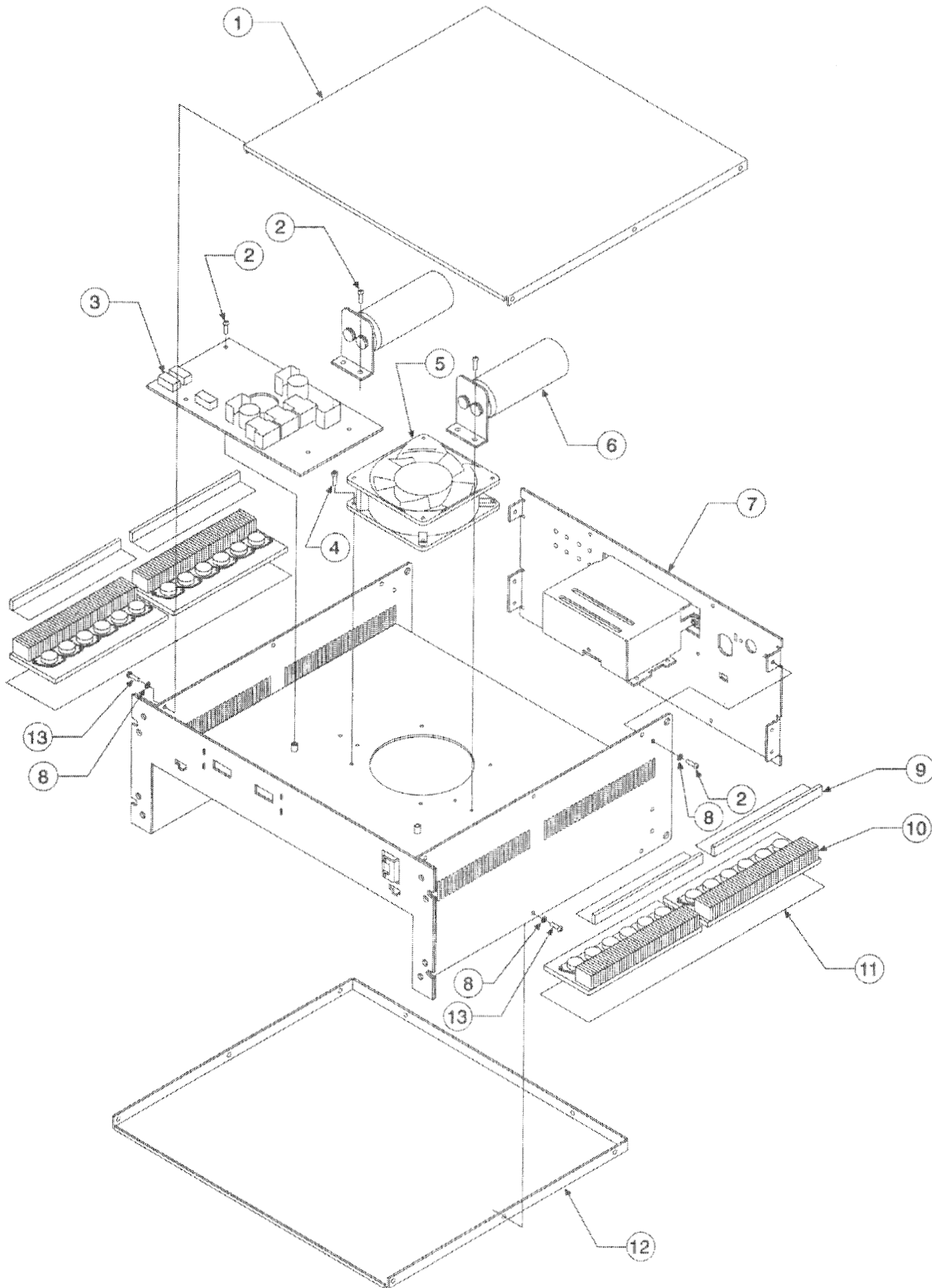

Figure 7.2 Top Main Assembly Parts

Top Main Assembly

See Figure 7.2

Item #	Description	Part # (CPN)	Qty.	Notes
1,12	Cover	F12873-0	2	Top/Bottom
2	Screw, 6-32 x .312	C 9491-9	26	
3	Control Module, REF I	Q43450-8	1	
	Control Module, REF II	Q43183A3	1	
4	Screw, 6-32 x .625 Skt Cap	A10092-10610	4	Mounts Fan
5	Fan	C 7858-1	1	
6	Capacitor Assembly	—	2	See Page 7-13
7	Back Panel Assembly	—	1	See Page 7-9
8	Washer, #6 Int. Star, Black	A10094-3	10	
9	Top Shield Fin Guard	F11697-4	4	
10	Output Assembly	—	2	See Page 7-11
11	Silpad	—	2	See Page 7-11
13	Screw, 6-32 x 3/8 PNHD Tri	C10451-0	24	Covers, etc.

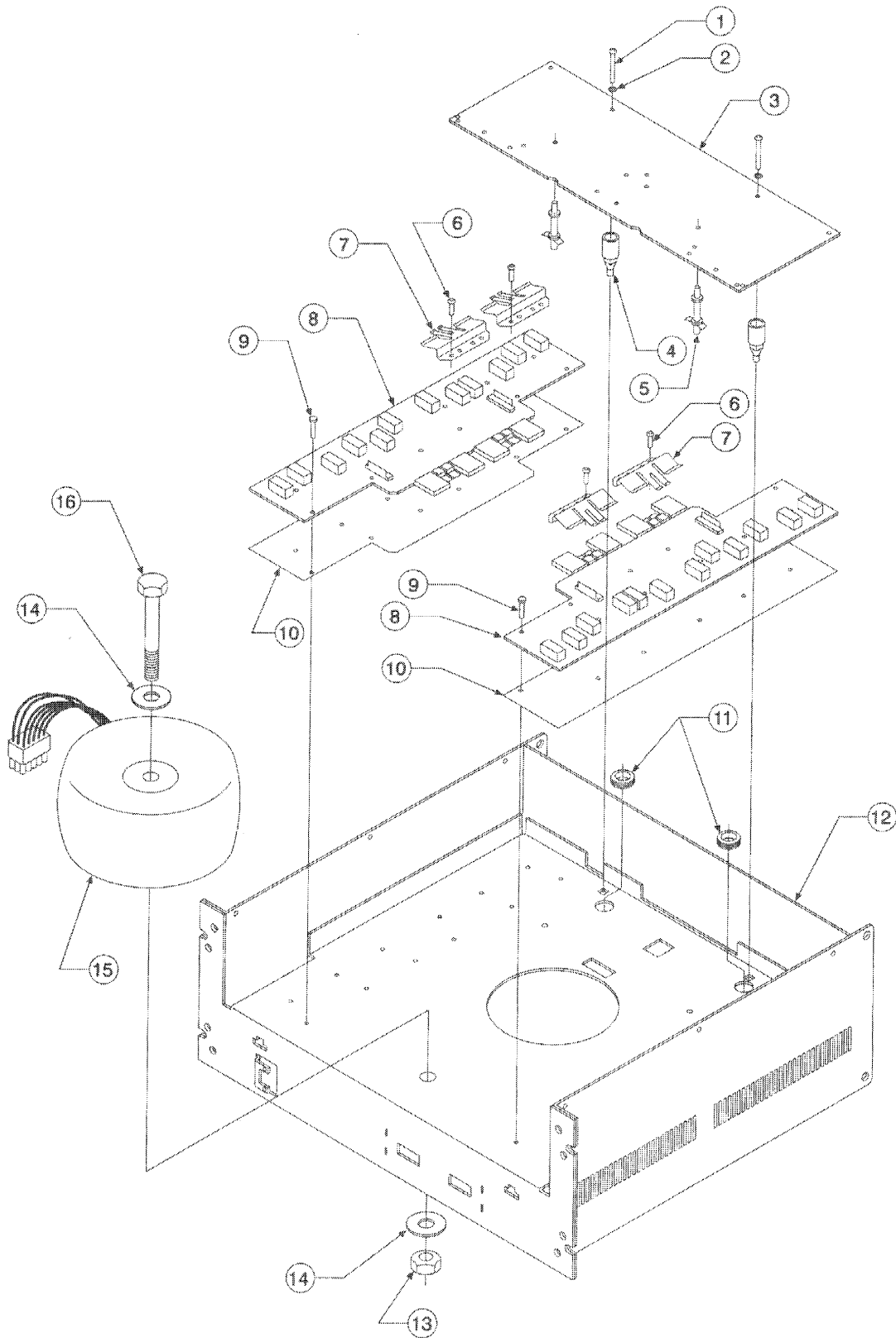

Figure 7.3 Bottom Main Assembly Parts

Bottom Main Assembly

See Figure 7.3

Item #	Description	Part # (CPN)	Qty.	Notes
1	Screw, 8-18 x 1.375 PNHD	A10109-10822	2	Main Board
2	Nylon Washer	D4137-2	2	
3	Main Module	—	1	See Sec. 8
4	Spacer, .875 Toggle Nut Plastic	C 6873-1	2	
5	Board Support, 7/8 Lock	C 7862-3	2	
6	Screw, 6-32 x .312 Pan Hd. T15	C 9491-9	12	
7	Clamp, TO-220/TO-3P	D8300-2	4	
8	Output Assembly	—	2	See Page 7-11
9	Screw, 6-32 x .56 Washer Head T15	A10315-1	24	
10	Output Pad	D7839-0	2	
11	1 x .625 Rubber Grommet	A10224-6	2	
12	Back Panel Assembly	—	1	See Page 7-9
13	Nut, 1/2-20	A10102-19	1	
14	Washer, 1/2 Steel	A10100-25	2	
15	Power Transformer, REF I	102097-1	1	
	Power Transformer, REF II	102098-1	1	
16	Screw, 1/2-20 x 4 Hex Cap	A10161-4	1	

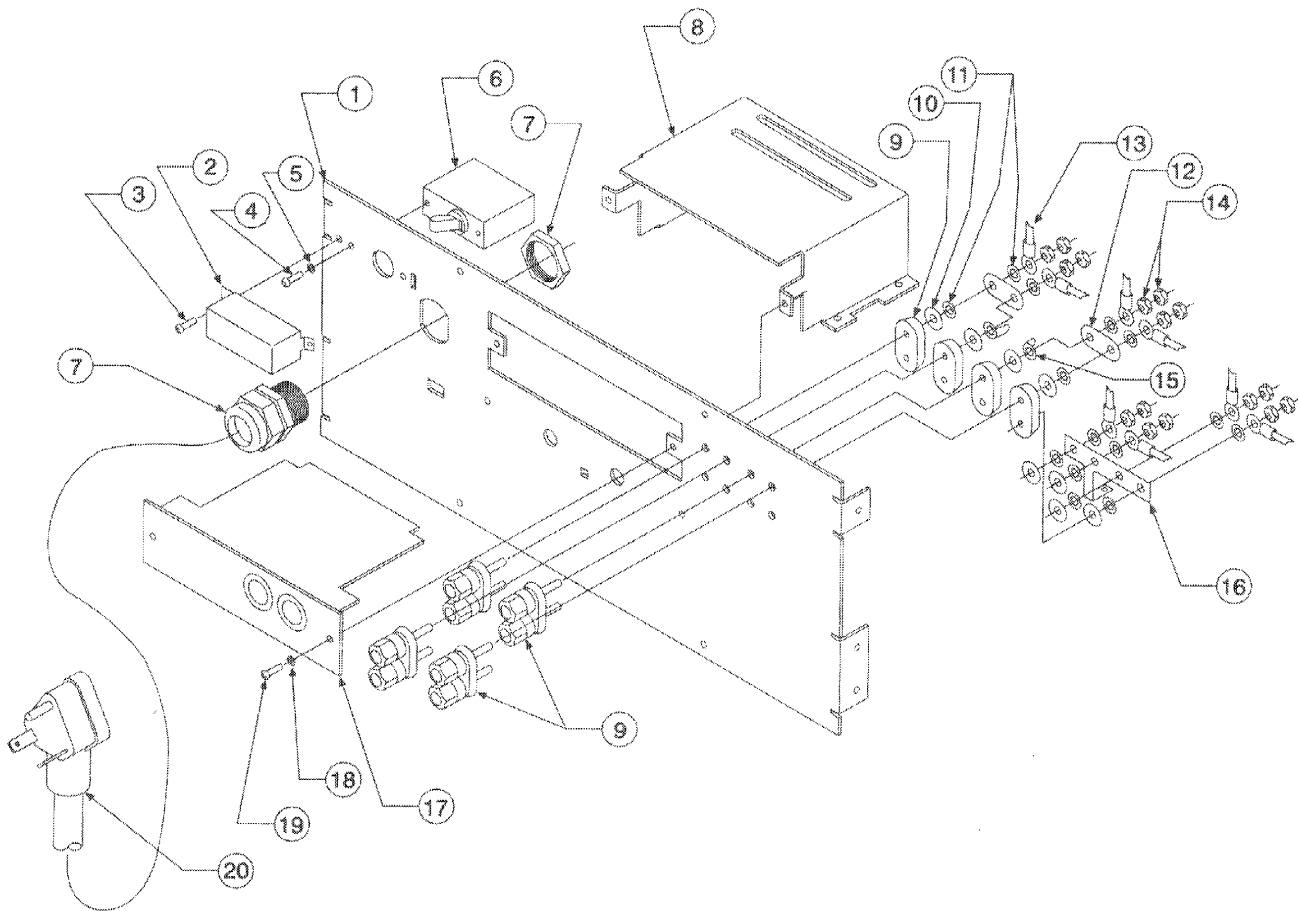

Figure 7.4 Back Panel Assembly Parts

Back Panel Assembly

See Figure 7.4

Item #	Description	Part # (CPN)	Qty.	Notes
1	Back Panel Plate	F12874-8	1	
2	Shield, Circuit Breaker	F11624J7	1	
3	Screw, 6-32 x 3/8 PNHD	C10451-0	1	Breaker Cover
4	Screw, 6-32 x .25	A10086-70604	2	
5	Washer, #6 Int. Star	A10094-3	2	
6	REF I Circuit Breaker, 30A	C 7756-7	1	
	REF II Circuit Breaker, 20A	C10193-8	1	
7	Strain Relief	F11160-3	1	
8	Pip Cage Assembly	—		See Pg. 7-14
9,10,11,14	Dual Binding Post, Gold Pltd	C 8013-2	4	
12	Jumper, 2 Position	F12812-8	2	
13	Wire, #12 BLK 22 in.	D 8846-4	2	W/Ring Term
	Wire, #12 BLK 15 in.	D 8847-2	2	W/Ring Term
	Wire, #12 RED 20 in.	D 8848-0	2	W/Ring Term
	Wire, #12 RED 13 in.	D 8849-8	2	W/Ring Term
15	Solder Lug, #8 Hole	D 2935-1	2	
16	Jumper, Four Output Ground	D 8855-5	1	
17	PIP-FX Input Connector	M44018-6	1	Standard PIP
18	Washer, #8 Star	A10094-5	2	PIP Module
19	Screw, 8-32 x .37 RDHD	A10086-70806	2	PIP Module
20	REF I Power Cord, 10-3 TT30P	A11793-0507F	1	
	REF II Power Cord, 12-3 W/15A	D 7538-8	1	

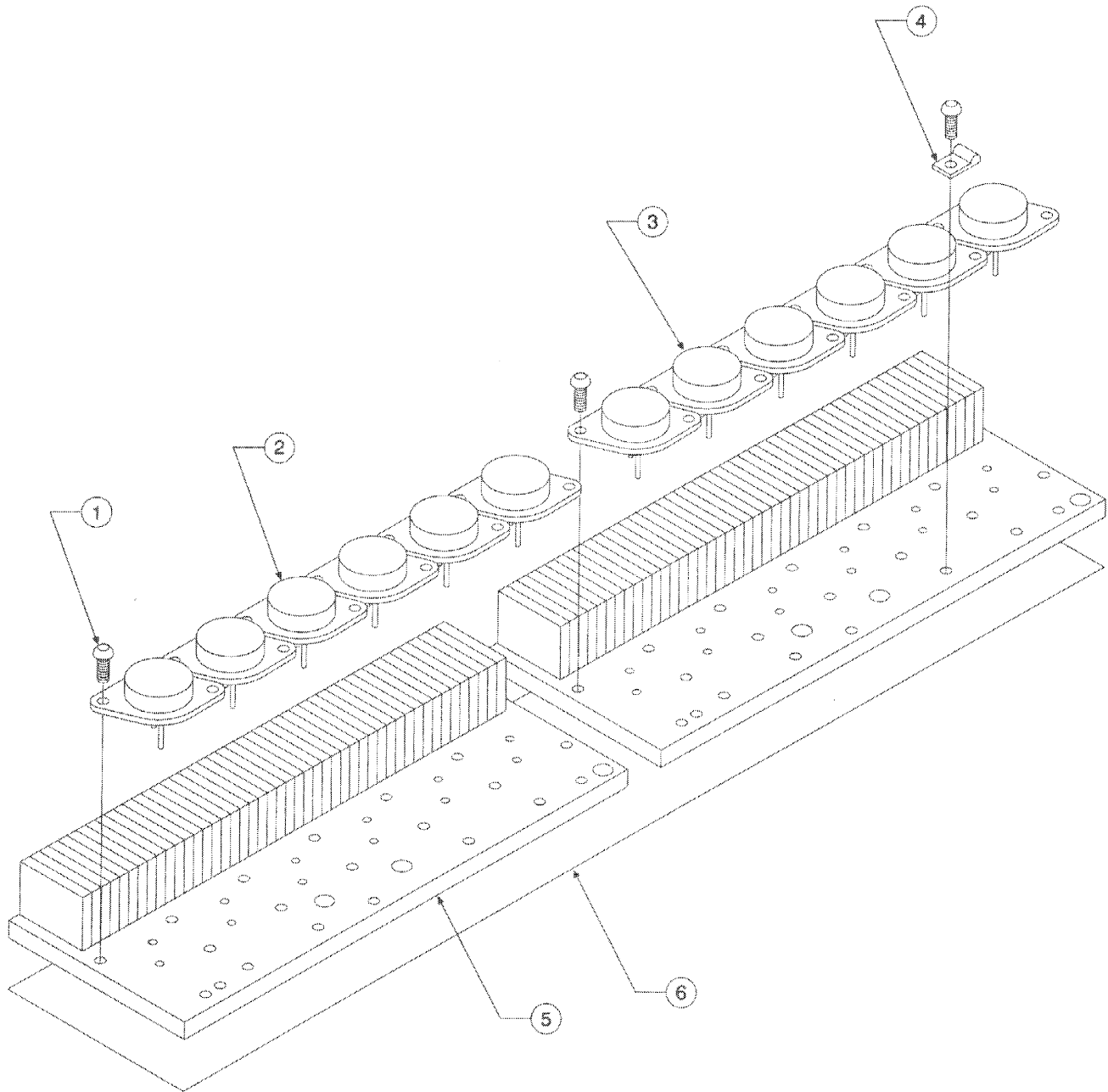

Figure 7.5 Output Assembly Parts

Output Assembly

See Figure 7.5

Item #	Description	Part # (CPN)	Qty.	Notes
1	Screw, 6-32 x .312 T15	C 9491-9	29	
2	NPN Power Transistor, REF I	C 8187-4	6	
	NPN Power Transistor, REF II	C 4751-1	6	
3	PNP Power Transistor, REF I	C 8188-2	6	
	PNP Power Transistor, REF II	C 6492-0	6	
4	PTC, 95 Deg C	D 8774-8	1	
5	Heatsink with Fins, REF I	M21322J8	2	
	Heatsink with Fins, REF II	M21324-5	2	
6	Sil Pad, 2.87 x 14.57 7 Mil	D 7796-2	1	

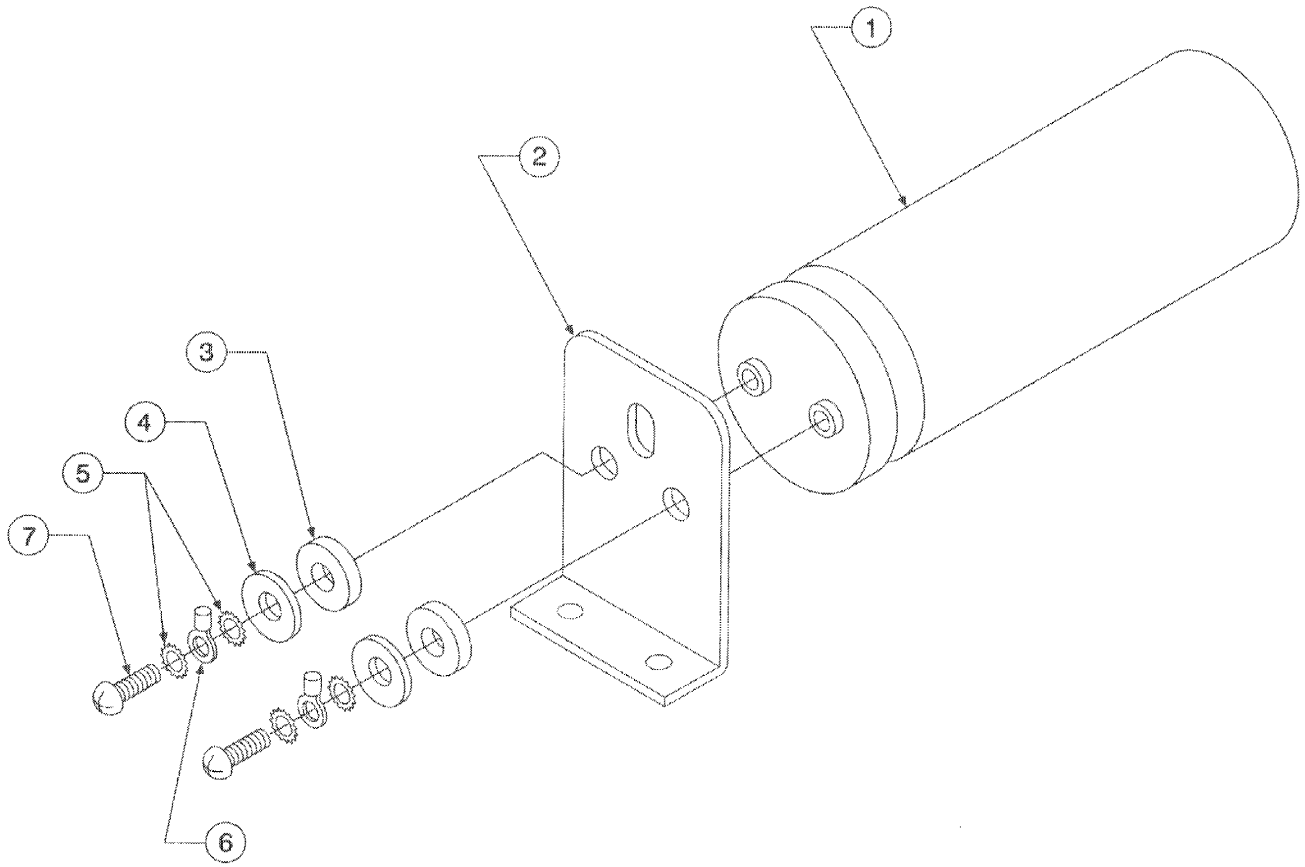

Figure 7.6 Capacitor Assembly Parts

Capacitor Assembly

See Figure 7.6

Item #	Description	Part # (CPN)	Qty.	Notes
1	Capacitor, 6300 μ F 150V (REF I)	D 8639-3	1	
	Capacitor, 10000 μ F 100V (REF II)	C 6485-4	1	
2	Bracket	F12474-7	2	
3	Shoulder Washer	D 6764-1	2	
4	Washer, 1/4" Belleville Spring	A10098-5	2	
5	Lock Washer, #10 Int. Tooth	A10094-8	4	
6	Wire, #16 Blue (Ch 1)	H43480-5	1	Ch 1 Only
	Wire, #16 Blue (Ch 2)	H43483-9	1	Ch 2 Only
	Wire, #16 Red (Ch 1)	H43481-3	1	Ch 1 Only
	Wire, #16 Red (Ch 2)	H43482-1	1	Ch 2 Only
7	Screw, 10-32 x .5	A10086-11008	2	

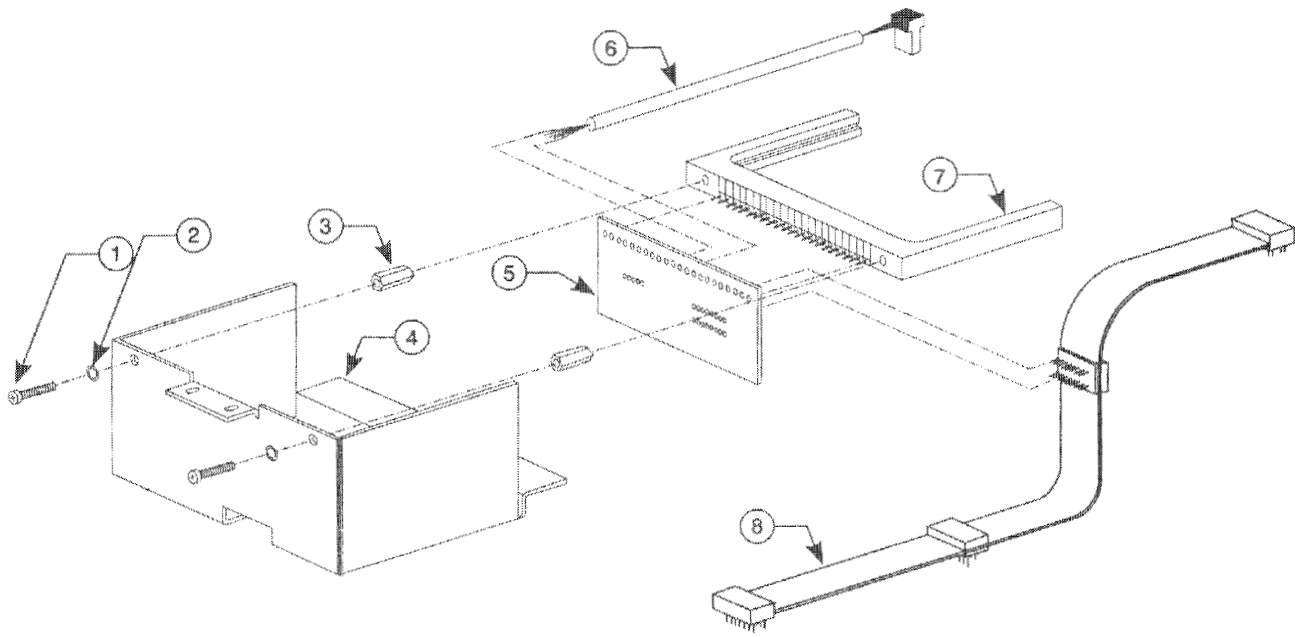

Figure 7.7 PIP Cage Assembly Parts

PIP Cage Assembly

See Figure 7.7

Item #	Description	Part # (CPN)	Qty.	Notes
1	Screw, 4-40 x .62 RDHD	A10086-10410	2	
2	#4 Star Lockwasher	A10094-2	2	
3	Aluminum Spacer	A10100-7	2	
4	PIP Shield	M21271J7	1	
5	PWB, PIP Interconnect	101240-1	1	
6	10" PIP Cable	D7623-8	1	
7	22 Contact Edge Connector	C6821-0	1	
8	PIP Daisy Ribbon Connector	D6899-5	1	

This page intentionally left blank

8 Module Information

8.1 General Information

Since the introduction of the Studio Reference amplifiers, there has been several updates and revisions. Some of these updates required new modules. This list of modules is complete up to this date, August 1996.

Following the module information is the parts list for each module. Included in the parts list is a map location. Refer to the component map at the end of each parts list for location of each component.

An important part of the parts list is the Circuit Designation. Below is a code to help determine what type of part each designation is:

C = Capacitor
 D = Diode
 E = LED
 HW = Hardware
 J = Socket or Connector
 K = Relay
 L = Inductor
 N = Resistor Network
 P = Terminal
 Q = Transistor
 R = Resistor
 S = Switch
 TP = Test Point
 U = Integrated Circuit
 X = Misc.
 Z = Jumper

If, in the circuit designation, there are two numbers the first is for channel 1 of the amplifier and the second is for channel 2. The parts will be identical and there will be two map locations. The first for channel 1 and the second for channel 2.

C.P.N. stands for Crown Part Number. When ordering a specific part refer to this number. You may reach the Crown parts department at (219) 294-8200 or 1-800-342-6939.

8.2 Studio Reference I Module Information

Main Module:

Q43371-6 main module built on PC board D 8825-8 or D 8920-7. For schematic see J 0674-2. For parts list see page 8-2.

Output Module:

Q43369-0 output module built on PC board P10423-5. For schematic see J 0674-2. For parts list see page 8-8.

Control Module:

Q43183A3 control module built on PC board D 8165A7. For schematic see J 0558A5. For parts list see page 8-11.

Q43450-8 control module built on PC board D 8853-0. For schematic see J 0696-5. For parts list see page 8-14.

Q43504-2 control module built on PC board D 9099-9. For schematic see J 0739-3. For parts list see page 8-17.

Display Module:

Q43018-3 display module built on PC board D 7940-6. For schematic see J 0510-8. For parts list see page 8-20.

8.3 Studio Reference II Module Information

Main Module:

Q43311-2 main module built on PC board D 8688-0. For schematic see J 0652-8. For parts list see page 8-23.

Q43388-0 main module built on PC board D 8825-8 or D 8920-7. For schematic see J 0652-8. For parts list see page 8-28.

Output Module:

Q43389-8 output module built on PC board P10423-5. For schematic see J 0652-8. For parts list see page 8-33.

Control Module:

Q43183A3 control module built on PC board D 8165A7. For schematic see J 0558A5. For parts list see page 8-11.

Q43450-8 control module built on PC board D 8853-0. For schematic see J 0696-5. For parts list see page 8-14.

Q43504-2 control module built on PC board D 9099-9. For schematic see J 0739-3. For parts list see page 8-17.

Display Module:

Q43312-0 display module built on PC board D 7940-6. For schematic see J 0510-8. For parts list see page 8-36.

8 Module Information

8.4 043371-6 Main Module Parts List

Cfr. Des.	C.P.N.	Description	Map Loc				
C1	C 5362-6	2.2uF 50V	14	C150/250	--- Not Used ---		O5/D5
C2	C 3913-8	470uF 35V	G4	C151/251	C 6806-1	.01uF 100V	L5/A5
C4	C 6802-0	.47uF 50V	15	C152/252	C 6811-1	100pF 200V	N4/C4
C7	C 6804-6	.1uF 35V	D2	C153/253	C 6804-6	.1uF 50V	J2/F2
C100/200	C 8576-8	100uF 35V	J2/F2	C154/254	C 8426-6	.1uF 250V	N5/B5
C101/201	C 8338-3	47pF 300V	J3/E2	C155/255	C 6804-6	.1uF 50V	K2/E2
C102/202	C 8576-8	100uF 35V	J5/F5	C156/256	C 6804-6	.1uF 50V	N1/A1
C103/203	C 6805-3	.022uF 100V	I3/F3	C157/257	C 6813-7	27pF 200V	J3/F3
C104/204	C 6805-3	.022uF 100V	J3/G3	C159/259	C 8551-1	.01uF 400V	I2/G2
C105/205	C 6813-7	27pF 200V	M3/A3	C160/260	C 6811-1	100pF 200V	M4/A4
C106/206	C 6813-7	27pF 200V	N3/C3	C161/261	C10176-3	33pF 200V	O4/C5
C107/207	C 7870-6	.33uF 63V	I5/G5	C162/262	C10176-3	33pF 200V	L5/A4
C108/208	C 6813-7	27pF 200V	N4/B4				
C109/209	C 8576-8	100uF 35V	K5/E5				
C110/210	C 5362-6	2.2uF 50V	J5/F5				
C111/211	C 6807-9	.001uF 100V	J3/F3				
C112/212	C 8581-8	.27uF 100V	N2/B2				
C113/213	C 9465-3	10uF 50V	N2/B2				
C114/214	C 8576-8	100uF 35V	N2/B2*				
C115/215	C 8576-8	100uF 35V	N1/B1				
C116/216	C 9465-3	10uF 50V	N1/B1				
C117/217	C 8581-8	.27uF 100V	M1/B1				
C118/218	C 6813-7	27pF 200V	N4/B4				
C119/219	C 6802-0	.47uF 50V	J5/F5				
C120/220	C 6804-6	.1uF 50V	O4/D4				
C121/221	C 6804-6	.1uF 50V	L4/A4				
C122/222	C10176-3	33pF 200V	O4/D5				
C123/223	C 6808-7	470pF 100V	J3/F3				
C124/224	C10176-3	33pF 200V	L5/A4				
C129/229	C 6812-9	47pF 100V	J4/F3				
C130/230	C 6814-5	12pF 200V	J5/F5				
C131/231	C 6814-5	12pF 200V	J4/F5				
C132/232	C 6806-1	.01uF 100V	L3/D3				
C133/233	C 6813-7	27pF 200V	H2/G2				
C134/234	C 6805-3	.022uF 100V	N2/A2				
C135/235	C 6805-3	.022uF 100V	L3/D3				
C136/236	C 6808-7	470pF 100V	O2/A2				
C137/237	C 6808-7	470pF 100V	L2/D2				
C138/238	C 6812-9	47pF 100V	I3/G3				
C139/239	C 6812-9	47pF 100V	I3/G3				
C140/240	C 6814-5	12pF 200V	N3/B3				
C141/241	C 6814-5	12pF 200V	N3/B3				
C143/243	C 6808-7	470pF 100V	N4/C4				
C144/244	C 8576-8	100uF 35V	I2/G2				
C145/245	C 6812-9	47pF 100V	J2/F2				
C146/246	C 6812-9	47pF 100V	J3/F3				
C147/247	--- Not Used ---		N3/C3				
C148/248	C 6808-7	470pF 100V	M4/A4				
C149/249	C 6807-9	.001uF 100V	N4/B4				

*For board D 8920-7 C114 map location is M2, and C214 is C2.

8 Module Information

E100/200	C 9857-1	Red LED	J5/F5	Q121/221	C 7458-0	2N4123	O4/D4
E101/201	C 9857-1	Red LED	J6/F6	Q122/222	C 3625-8	2N4125	L3/A3
HW16	C 8812-7	5.5" Cable Tie	A5	Q123/223	C 3625-8	2N4125	K4/E4
HW17	C 8812-7	5.5" Cable Tie	B5	Q124/224	C 3786-8	MPS4250A	M5/B5
HW18	C 8812-7	5.5" Cable Tie	N5	Q125/225	C 5891-4	MTS105 Therm	N5/C5
HW19	C 8812-7	5.5" Cable Tie	O5	Q126/226	C 3625-8	2N4125	K6/E6
J2	C 4508-5	16 Pin IC Skt.	H4	Q127/227	C 7458-0	2N4123	K6/E6
J100/200	C 8432-4	3 Cond Ph Jk	I1/G1	Q128/228	C 3625-8	2N4125	K5/E5
J100X/200XC	C 6778-2	Ph Jk Cover	I1/G1	Q129/229	C 7458-0	2N4123	K5/E5
J500	D 8395-2	7.75" 12pin Cbl	O5	Q130/230	C 3625-8	2N4125	K5/E5
J600	D 8397-8	2.5" 12pin Cbl	N5	Q131/231	C 3625-8	2N4125	L3/D3
J700	D 8397-8	2.5" 12pin Cbl	B5	Q132/232	C 3625-8	2N4125	K3/D3
J800	D 8395-2	7.75" 12pin Cbl	A5	Q133/233	C 3625-8	2N4125	O4/D4
N101/201	D 8248-3	7 pin Res Net	M2/C2	Q134/234	C 7458-0	2N4123	L3/A3
N102/202	D 6082-8	Res Net-C	J4/E4	Q135/235	C 3810-6	MPSA42/43	K4/E4
N101A/201A	--- Not Used ---		M2/C2	Q136/236	C 3578-9	MPSA93	K4/D5
N101B/201B	--- Not Used ---		M2/C2	R1	A10265-10021	10K 1%	E2
N101C/201C	--- Not Used ---		M2/C2	R4	A10265-10521	10.5K 1%	D1
N101D/201D	--- Not Used ---		M2/C2	R5	--- Not Used ---		H4
N101E/201E	--- Not Used ---		M2/C2	R7	A10266-4331	43K 5%	I6
N101F/201F	--- Not Used ---		M2/C2	R8	A10265-75021	75K 1%	H6
P1	C 7593-4	5pos Header	H2	R10	--- Not Used ---		D2
P6	C 8418-3	3pos Header	H2	R11	--- Not Used ---		L5
P11	C 7593-4	5pos Header	H5	R12	--- Not Used ---		D5
P12	--- Not Used ---		G4	R17	A10265-75021	75K 1%	H6
P101/201	C 7592-6	4pos Header	J1/F1	R18	A10266-4331	43K 5%	G6
Q100/200	D 2961-7	2961	N3/C3	R19	A10266-2R72	2.7 5% .5W	I4
Q101/201	C 8104-9	MPSW92	M3/B3	R100/200	--- Not Used ---		I3/G3
Q102/202	C 8103-1	MPSW42	N3/C3	R101/201	A10265-10211	1.02K 1%	J2/F2
Q103/203	C 3625-8	2N4125	M3/B3	R102/202	A10266-5111	510 5%	J3/F3
Q104/204	C 8104-9	MPSW92	N4/C4	R103/203	A10265-20523	20.5K 1% 1W	J2/F2
Q105/205	C 8104-9	MPSW92	N4/C4	R104/204	A10265-26711	2.67K 1%	M3/A3
Q106/206	C 3625-8	2N4125	O3/A3	R105/205	A10265-26711	2.67K 1%	N3/C3
Q107/207	C 3786-8	MPS4250A	M4/B4	R106/206	A10265-11821	11.8K 1%	L3/A3
Q108/208	C 5891-4	MTS105 Therm	N4/C4	R107/207	A10266-6831	68K 5%	M3/A3
Q109/209	D 2961-7	2961	K3/E3	R108/208	A10266-8211	820 5%	N4/C4
Q110/210	C 8103-1	MPSW42	M4/B4	R109/209	A10266-9101	91 5%	N4/C4
Q111/211	C 8103-1	MPSW42	M4/B4	R110/210	A10266-6831	68K 5%	N3/C3
Q112/212	C 3625-8	2N4125	J4/E4	R111/211	A10265-11821	11.8 1%	O3/D3
Q113/213	C 3625-8	2N4125	J4/F4	R112/212	A10265-49921	49.9K 1%	H3/G3
Q114/214	C 7458-0	2N4123	K3/E3	R113/213	A10265-48711	4.87K 1%	J4/F4
Q115/215	D 2962-5	MPSA18	O5/D5	R114/214	A10266-1521	1.5K 5%	I4/G4
Q116/216	C 3786-8	MPS4250A	L5/A5	R115/215	A10266-5141	510K 5%	L2/D2
Q117/217	D 2961-7	2961	O3/A3	R116/216	A10266-3351	3.3M 5%	J4/F4
Q118/218	D 2961-7	2961	O3/A3	R117/217	A10266-4731	47K 5%	H3/G3
Q119/219	C 3625-8	2N4125	K3/E3	R118/218	A10265-40201	402 1%	N4/B4
Q120/220	C 3625-8	2N4123	K3/E3	R119/219	A10265-12111	1.21K 1%	N5/C5
				R120/220	A10265-40201	402 1%	N4/B4
				R121/221	C 5062-2	100K LIN POT	O1/A1
				R122/222	A10266-2741	270K 5%	N2/A2
				R123/223	A10266-2032	20K 5% .5W	O2/A2

8 Module Information

R124/224	A10266-6821	6.8K 5%	O1/A1	R176/276	A10265-10721	10.7K 1%	J2/F2
R125/225	A10266-1011	100 5%	O2/A2	R177/277	A10265-60411	6.04K 1%	H3/G3
R126/226	A10266-1011	100 5%	O2/A2	R179/279	A10266-1321	1.3K 5%	K4/E4
R127/227	A10266-6821	6.8K 5%	N3/A3	R180/280	A10266-4711	470 5%	M3/A3
R128/228	A10266-1331	13K 5%	N2/A2	R181/281	A10265-48711	4.87K 1%	N4/B4
R129/229	A10266-1041	100K 5%	N3/A3	R182/282	A10266-2201	22 5%	J2/F2
R130/230	A10266-1041	100K 5%	L3/D3	R183/283	A10266-4731	47K 5%	O3/D3
R131/231	A10266-1331	13K 5%	L3/D3	R184/284	A10266-4741	470K 5%	K5/D5
R132/232	C 5062-2	100K LIN POT	K1/E1	R185/285	A10266-4731	47K 5%	O4/D3
R133/233	A10266-2741	270K 5%	K2/E2	R186/286	A10266-2751	2.7M 5%	J5/F5
R134/234	A10266-2032	20K 5% .5W	M3/C3	R187/287	A10266-3321	3.3K 5%	K6/E6
R135/235	A10266-1011	100 5%	K2/E2	R188/288	A10266-3321	3.3K 5%	K6/E6
R136/236	A10266-6821	6.8K 5%	L2/D2	R189/289	A10266-2731	27K 5%	K5/E5
R137/237	A10266-1011	100 5%	K2/E2	R190/290	A10266-2051	2M 5%	J5/F6
R138/238	A10266-6821	6.8K 5%	L3/D3	R191/291	A10266-4731	47K 5%	L3/A3
R139/239	A10266-8211	820 5%	M4/A4	R192/292	A10266-4731	47K 5%	L3/A3
R140/240	A10266-9101	91 5%	M4/A4	R193/293	A10265-10021	10K 1%	J5/F5
R141/241	A10266-1541	150K 5%	N3/A3	R194/294	A10265-20021	20K 1%	J2/F2
R142/242	A10266-1541	150K 5%	L3/D3	R195/295	A10266-4701	47 5%	K4/F3
R143/243	A10266-4711	470 5%	K6/D6	R196/296	A10266-3921	3.9K 5%	K4/E4
R144/244	A10266-4711	470 5%	K5/D5	R197/297	A10265-10021	10K 1%	K4/E4
R145/245	A10266-4711	470 5%	K6/E6	R198/298	A10266-3921	3.9K 5%	K3/E3
R146/246	A10265-11821	11.8K 1%	O4/D4	R199/299	A10265-10021	10K 1%	K3/E3
R147/247	A10124-24	#24 Buss Wire	O5/D5	R500/600	A10266-3041	300K 5%	J3/F3
R148/248	A10265-20011	2K 1%	N4/C4	R501/601	A10266-3041	300K 5%	J3/F3
R149/249	A10266-1012	100 5% .5W	L5/A5	R502/602	A10266-3041	300K 5%	J3/F3
R150/250	A10265-20011	2K 1%	M4/A4	R503/603	A10266-4702	47 5% .5W	J2/F2
R151/251	A10265-11821	11.8K 1%	L4/A4	R504/604	A10266-5141	510K 5%	L2/D2
R152/252	A10265-11821	11.8K 1%	O2/A2	R505/605	A10266-5141	510K 5%	L2/D2
R153/253	A10124-24	#24 Buss Wire	J4/G3	R506/606	A10266-1521	1.5K 5%	J5/F5
R154/254	A10266-5601	56 5%	K5/D5	R507/607	A10266-4711	470 5%	J5/F5
R155/255	A10266-4731	47K 5%	J4/F4	R508/608	A10266-2731	27K 5%	J5/F5
R156/256	A10266-1321	1.3K 5%	N2/A2	R509/609	A10265-49911	4.99K 1%	I3/G3
R157/257	A10266-1321	1.3K 5%	L2/D2	R510/610	A10265-49911	4.99K 1%	H2/G2
R158/258	A10266-9121	9.1K 5%	K2/E2	R511/611	A10265-49911	4.99K 1%	H2/G2
R159/259	A10266-1331	13K 5%	J3/F3	R512/612	C 9079-2	200/220 Pot	H3/H3
R160/260	A10266-5601	56 5%	K6/D6	R513/613	A10265-49911	4.99K 1%	H3/G3
R161/261	A10266-4701	47 5%	N3/B3	R514/614	C 7340-0	24 5% 3W	H1/H1
R162/262	A10266-4701	47 5%	N3/B3	R515/615	A10266-1821	1.8K 5%	J1/F1
R163/263	A10266-5601	56 5%	K5/D5	R516/616	A10266-1051	1M 5%	L2/D2
R164/264	A10266-4711	470 5%	K5/D5	R517/617	A10266-9101	91 5%	N4/B4
R165/265	A10266-4711	470 5%	K5/D6	R518/618	A10266-9101	91 5%	N4/B4
R166/266	A10266-4711	470 5%	K5/D5	R519/619	A10265-12111	1.21K 1%	M5/A5
R167/267	A10265-10011	1K 1%	O2/A2	R520/620	A10266-1521	1.5K 5%	M5/A5
R168/268	A10265-95301	953 1%	O2/A2	R521/621	A10265-11021	11K 1%	N5/B5
R169/269	A10266-1041	100K 5%	N3/C3	R522/622	A10266-4741	470K 5%	M5/A5
R170/270	A10265-10011	1K 1%	K3/E3	R523/623	A10266-1521	1.5K 5%	N5/C5
R171/271	A10265-95301	953 1%	K3/E3	R524/624	A10266-4741	470K 5%	N5/C5
R172/272	A10266-1041	100K 5%	M3/A3	R525/625	A10265-11021	11K 1%	N5/B5
R173/273	A10266-5601	56 5%	K5/D5	R526/626	A10265-10021	10K 1%	I5/F5
R174/274	A10265-10721	10.7K 1%	I2/G2	R527/627	A10266-3921	3.9K 5%	L4/D4
R175/275	A10265-26711	2.67K 1%	H2/G2	R528/628	A10265-10021	10K 1%	L4/D4

8 Module Information

R529/629	A10266-4731	47K 5%	L4/D4	U1	C 5095-2	MC7815CT	H5
R530/630	A10265-10021	10K 1%	O3/D4	U1X	C 9494-3	Heatsink	H5
R531/631	A10266-4731	47K 5%	L3/D3	U2	C 5096-0	MC7915CT	G5
R532/632	A10265-10021	10K 1%	L4/A4	U2X	C 9494-3	Heatsink	G5
R533/633	A10265-10021	10K 1%	O3/D3	U100/200	C 6911-9	UPA75	N2/B2
R534/634	A10265-10021	10K 1%	L3/A3	U101/201	C 6411-0	H11C2	J5/E5
R535/635	A10266-1R01	1 5%	O5/A5	U101X/201X	C 8019-9	6 pin IC Skt	J5/E5
R536/636	A10266-4701	47 5%	K5/E5	U102/202	C 4345-2	LM339N	I5/G5
R537/637	A10265-10021	10K 1%	K4/D4	U102X/202X	C 3450-1	14 pin IC Skt	I5/G5
R538/638	A10265-10021	10K 1%	L4/D5	U103/203	C 6910-1	UPA76	L2/D2
R539/639	--- Not Used ---		J1/F1	U104/204	C 7558-7	MC33079P	I3/F3
R540/640	--- Not Used ---		J1/E1	U104X/204X	C 3450-1	14 pin IC Skt	I3/F3
R541/641	--- Not Used ---		I2/G2	U100B/200B	--- Not Used ---		N2/B2
R542/642	--- Not Used ---		I3/G3	U103B/203B	--- Not Used ---		L2/D2
R543/643	--- Not Used ---		J5/F5				
R544/644	A10266-2031	20K 5%	L4/E4	Z01	--- Not Used ---		D1
R545/645	A10266-2031	20K 5%	M4/D4	Z02	--- Not Used ---		C1
				Z03	--- Not Used ---		C1
S2	C 7325-1	DPDT Switch	H1	Z04	--- Not Used ---		C2
S3	C 7960-5	3 Pos Switch	H2	Z05	--- Not Used ---		C2
S4	C 6781-6	6P3T Switch	C1				
TP1	C 6564-6	10P Header	L5	PC Board	D 8825-8	Main #2	
TP2	C 6564-6	10P Header	D5		or D 8920-7	Main #3	
TP3	C 9896-9	Test Point	F4				
TP4	C 9896-9	Test Point	I4				

This page intentionally left blank

8 Module Information

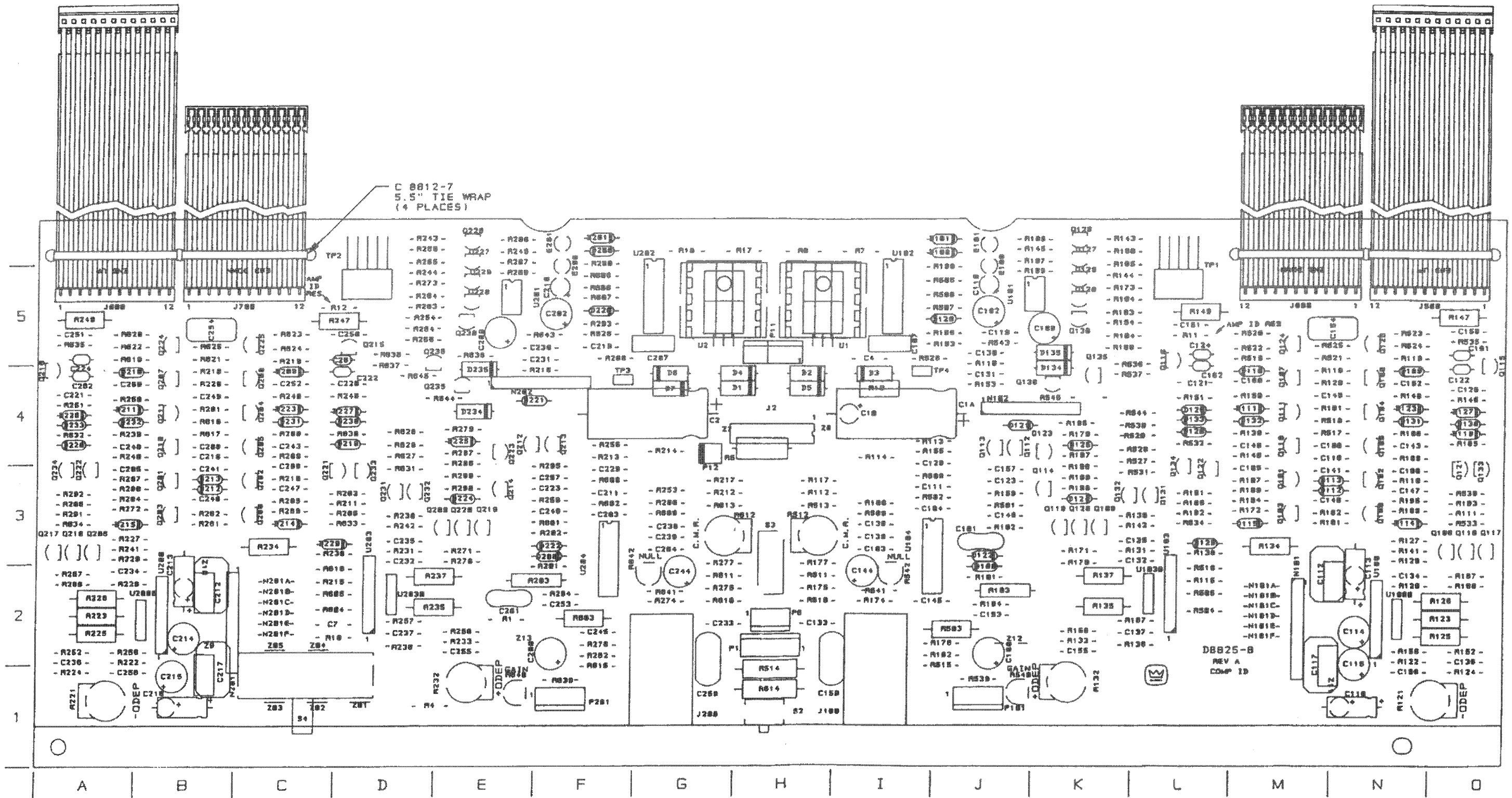

Figure 8.1 Q43371-6 Main Module Map

8 Module Information

8.5 Q43369-0 Output Module Parts List

<u>Cir. Des.</u>	<u>C.P.N</u>	<u>Description</u>	<u>Map Loc</u>				
C01	A10434-473JD	.047 μ F 250V	G1	P00	--- Not Used ---		F2
C02	C 8426-6	.1 μ F 250V	C2	P500	C 9828-2	12 Pin Header	E3
C03	C 8426-6	.1 μ F 250V	L2	P600	C 9828-2	12 Pin Header	J3
C04	C 6806-1	.01 μ F 100V	F4	Q00	C 4647-1	TIP47 NPN	I4
C05	C 6806-1	.01 μ F 100V	J4	Q01	C 8159-3	2SC4029 NPN	E5
C06	C 6806-1	.01 μ F 100V	G4	Q05	C 8186-6	2SA1553 PNP	J5
C07	C 6807-9	.001 μ F 100V	F3	Q12	C 8159-3	2SC4029 NPN	G5
C08	C 6810-3	180pF 100V	E3	Q16	C 8186-6	2SA1553 PNP	H5
C09	C 6809-5	220pF 100V	J3	Q17	C10155-7	2SC4793 NPN	F4
C10	C 6807-9	.001 μ F 100V	I4	Q18	C 4647-1	TIP47 NPN	F4
C11	C 6806-1	.01 μ F 100V	I4	Q19	C10156-5	2SA1837 PNP	I4
C12	--- Not Used ---		I4	R00	A10266-6801	68 5%	F4
C13	--- Not Used ---		G4	R01	A10266-1011	100 5%	E4
C13A	C 8991-9	.47 μ F 63V	D2	R02	C 7778-1	5.6 5% .5W FP	F3
C15	--- Not Used ---		F3	R03	C 6486-2	.2 5% 5W	E2
C16	C 8426-6	.1 μ F 250V	H4	R04	C 6486-2	.2 5% 5W	C2
D01	C 2851-1	1N4004	E3	R05	C 6486-2	.2 5% 5W	A1
D02	C 2851-1	1N4004	F3	R06	C 6486-2	.2 5% 5W	I2
D03	C 2851-1	1N4004	I3	R07	C 6486-2	.2 5% 5W	K2
D04	C 2851-1	1N4004	J3	R08	C 6486-2	.2 5% 5W	N1
D05	C 8383-9	GI822	A2	R09	C 7779-9	22 5% FP	J3
D06	C 8383-9	GI822	M2	R10	A10266-1011	100 5%	J4
D07	C 8383-9	GI822	B3	R11	C 6625-5	5.6 5% 5W	H2
D08	C 8383-9	GI822	K2	R12	A10266-2R74	2.7 5% 2W	C1
D15	C 2851-1	1N4004	A2	R13	A10266-6801	68 5%	J4
D16	C 2851-1	1N4004	N3	R14	A10266-2R74	2.7 5% 2W	M1
HW1	A10094-2	#4 Lockwasher	I1	R15	C 6486-2	.2 5% 5W	M1
HW2	A10094-2	#4 Lockwasher	I1	R16	C 6486-2	.2 5% 5W	E2
HW3	A10094-2	#4 Lockwasher	G2	R17	C 6486-2	.2 5% 5W	F1
HW4	A10094-2	#4 Lockwasher	G2	R18	C 6486-2	.2 5% 5W	B1
HW5	C 7481-2	4 Way Conn.	I1	R19	C 6486-2	.2 5% 5W	J1
HW6	C 7481-2	4 Way Conn.	G2	R20	C 6486-2	.2 5% 5W	H1
HW7	A10608-3	4-40X3/8 Spcr	I1	R21	C 7778-1	5.6 5% .5W FP	F1
HW8	A10608-3	4-40X3/8 Spcr	I1	R22	C 7779-9	22 5% FP	H3
HW9	A10608-3	4-40X3/8 Spcr	G2	R23	C 6844-2	250 Pot	H3
HW10	A10608-3	4-40X3/8 Spcr	G2	R24	A10266-1331	13K 5%	F4
HW11	D 8441-4	Fishpaper	E4-K4	R25	A10266-2221	2.2K 5%	F3
HW12	A10020-1	4-40X.25 Stud	I1	R26	C 6844-2	250 Pot	G4
HW13	A10020-1	4-40X.25 Stud	I1	R27	A10266-3911	390 5%	G4
HW14	A10020-1	4-40X.25 Stud	G2	R28	A10266-1331	13K 5%	I4
HW15	A10020-1	4-40X.25 Stud	G2	R29	A10266-5101	51 5%	F3
L00	D 7701-2	2.5 μ H Coil	G2	R30	A10265-10201	102 1%	D3
L01	C 3510-2	470 μ H Choke	F4	R31	C 6625-5	5.6 5% 5W	G2
L02	C 3510-2	470 μ H Choke	J4	R32	--- Not Used ---		C1
				R33	--- Not Used ---		C1
				R34	--- Not Used ---		B1
				R35	A10266-1R02	1 5% .5W	D4
				R36	A10266-1R02	1 5% .5W	K4
				R37	C 7779-9	22 5% FP	D3
				R38	C 7779-9	22 5% FP	D2

8 Module Information

R39	C 7779-9	22 5% FP	D3
R40	C 7779-9	22 5% FP	K3
R41	C 7779-9	22 5% FP	K3
R42	C 7779-9	22 5% FP	J3
R43	A10266-5101	51 5%	G4
R44	A10266-2021	2K 5%	H3
R45	A10266-7511	750 5%	I4
R46	--- Not Used ---		L1
R47	--- Not Used ---		L1
R48	--- Not Used ---		L1
R49	C 7779-9	22 5% FP	F2
R50	C 7779-9	22 5% FP	D2
R51	C 7779-9	22 5% FP	B2
R52	C 7779-9	22 5% FP	M2
R53	C 7779-9	22 5% FP	K2
R54	C 7779-9	22 5% FP	I2
Z3	C 5868-2	0 Ohm Jmp	D1
Z4	C 5868-2	0 Ohm Jmp	D3
Z8	C 5868-2	0 Ohm Jmp	D2
Z00	C 5868-2	0 Ohm Jmp	E1
Z01	C 5868-2	0 Ohm Jmp	E2
Z02	C 5868-2	0 Ohm Jmp	E3
Z03	C 5868-2	0 Ohm Jmp	E3
Z04	C 5868-2	0 Ohm Jmp	H3
Z05	C 5868-2	0 Ohm Jmp	H3
Z06	C 5868-2	0 Ohm Jmp	H3
Z07	C 5868-2	0 Ohm Jmp	I3
Z08	C 5868-2	0 Ohm Jmp	J3
Z09	C 5868-2	0 Ohm Jmp	J3
Z10	C 5868-2	0 Ohm Jmp	J2
Z11	C 5868-2	0 Ohm Jmp	J1
Z12	C 5868-2	0 Ohm Jmp	J2
Z13	C 5868-2	0 Ohm Jmp	J1
Z14	C 5868-2	0 Ohm Jmp	E3
Z15	C 5868-2	0 Ohm Jmp	J2
Z16	C 5868-2	0 Ohm Jmp	E3
Z17	C 5868-2	0 Ohm Jmp	H1
Z18	C 5868-2	0 Ohm Jmp	H1
PC Board	P10423-5	THC #2	

8 Module Information

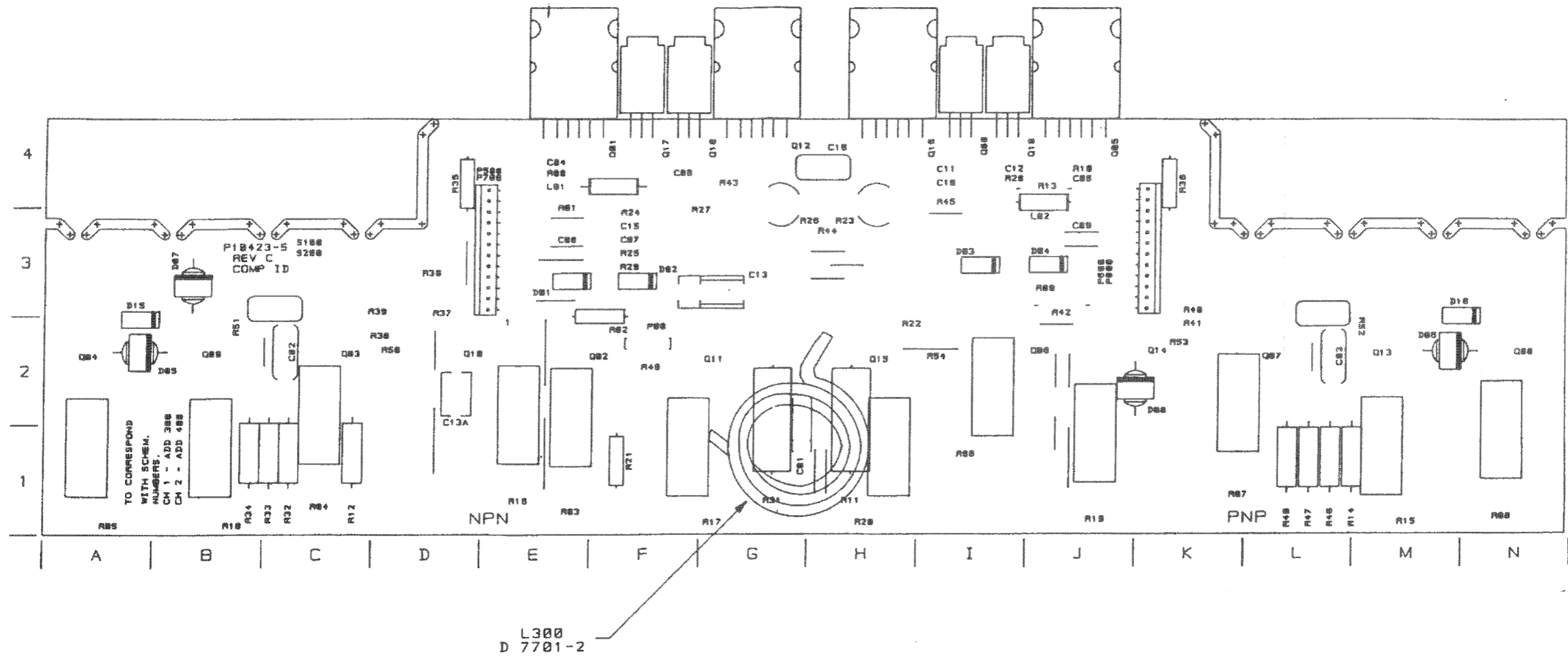

Figure 8.2 Q43369-0 Output Module Map

8 Module Information

8.6 Q43183A3 Control Module Parts List

<u>Cir. Des.</u>	<u>C.P.N.</u>	<u>Description</u>	<u>Map Loc</u>
C1	C 6804-6	.1 μ F 50V	D4
C2	C 6096-9	3.3 μ F 50V	D4
C3	C 7819-3	1800 μ F 35V	F1
C4	C 7819-3	1800 μ F 35V	F5
C5	C 5362-6	2.2 μ F 50V	E2
C6	C 5362-6	2.2 μ F 50V	E5
C7	C 9943-9	.1 μ F 250V	I2
C8	C 9943-9	.1 μ F 250V	H2
C9	C 9943-9	.1 μ F 250V	H2
C10	C 9943-9	.1 μ F 250V	I2
C11	C 6804-6	.1 μ F 50V	C4
C12	C 6804-6	.1 μ F 50V	C3
C13	C 8963-8	.47 μ F 250V	H4
D1	C 2851-1	1N4004	F3
D2	C 2851-1	1N4004	F3
D3	C 2851-1	1N4004	F3
D4	C 2851-1	1N4004	F2
D5	C 2851-1	1N4004	E2
D6	C 2851-1	1N4004	E5
D7	C 2851-1	1N4004	E2
D8	C 2851-1	1N4004	E5
D9	C 2851-1	1N4004	F1
D10	C 3181-2	1N4148	D3
D11	C 2851-1	1N4004	F2
D12	C 3181-2	1N4148	C2
D13	C 3181-2	1N4148	D2
D14	C 3181-2	1N4148	D2
D15	C 3181-2	1N4148	D2
D16	C 3181-2	1N4148	C2
D17	C 2851-1	1N4004	H3
D18	C 2851-1	1N4004	H3
D19	C 3549-0	1N961B, 10V	C3
D20	C 3181-2	1N4148	C1
D21	C 3181-2	1N4148	C2
D22*	C10437-9	Bridge Rect.	H1
D23*	C10437-9	Bridge Rect.	I1
D24*	C10437-9	Bridge Rect.	A3
D25*	C10437-9	Bridge Rect.	A4

*Not included with module, order separately.

HW1	A10086-10605	6-32X.3125	A4
HW2	A10086-10605	6-32X.3125	E2
HW3	A10086-10605	6-32X.3125	E5
HW5	A10094-4	#6 Lockwasher	A4
HW6	A10094-4	#6 Lockwasher	E2
HW7	A10094-4	#6 Lockwasher	E5
HW10	A10102-5	6-32 Hex Nut	A4

HW11	A10102-5	6-32 Hex Nut	E2
HW12	A10102-5	6-32 Hex Nut	E5
HW14	C 6510-9	T0220 HTSNK	A4
HW15	C 6510-9	T0220 HTSNK	E2
HW16	C 6510-9	T0220 HTSNK	E5
HW18	C 6541-4	T0220 Spreader	A4
HW19	C 6541-4	T0220 Spreader	E2
HW20	C 6541-4	T0220 Spreader	E5
HW25	H43267-6	Wires	H5 & I5
HW28	C 8982-8	Holder	G4
J3	C 4508-5	16 Pin Socket	A2
J4	C 4508-5	16 Pin Socket	A1
J12	C 4508-5	16 Pin Socket	C1
J13	C 9442-2	15 Pin Conn.	I4
J29	--- Not Used ---		B2
K1	C 9787-0	30A 24V Relay	G3
K2	C 9787-0	30A 24V Relay	G1
K3	C 9787-0	30A 24V Relay	G2
P13	C 7817-7	.25 Tab	F5
P14	C 7817-7	.25 Tab	I5
P15	C 7817-7	.25 Tab	H5
P16	C 7817-7	.25 Tab	I5
P17	C 7817-7	.25 Tab	I5
P18	C 7817-7	.25 Tab	J5
P19	C 7817-7	.25 Tab	G5
P20	C 7817-7	.25 Tab	I5
P21	C 7817-7	.25 Tab	G5
P26	C 7817-7	.25 Tab	G5
P27	C 7593-4	5 Pin Header	E1
P28	C 7592-6	4 Pin Header	D2
P50	C 7817-7	.25 Tab	H5
P51	C 7817-7	.25 Tab	H5
Q1	C 3625-8	2N4125	E1
Q2	C 3625-8	2N4125	E2
Q3	C 3625-8	2N4125	C3
Q4	C 7662-7	MAC218	H4
R1	C 8960-4	5 Ohm PTC	G4
R3	A10265-82521	82.5K 1%	D4
R4	C 3093-9	10K Helitrim	D4
R5	A10265-10031	100K 1%	H3
R6	A10265-10031	100K 1%	H4
R7	A10266-3331	33K 5%	D4
R8	--- Not Used ---		D4
R9	A10266-3921	3.9K 5%	D3
R10	A10266-2221	2.2K 5%	D2
R11	A10266-2221	2.2K 5%	C1
R12	A10266-4731	47K 5%	D4

8 Module Information

R13	A10266-2031	20K 5%	C4
R14	A10266-4731	47K 5%	C4
R15	A10266-1021	1K 5%	C4
R16	A10266-4731	47K 5%	C4
R17	A10266-3321	3.3K 5%	C3
R18	A10266-1231	12K 5%	C3
R19	A10265-11031	110K 1%	C3
R20	A10266-4721	4.7K 5%	D2
R21	A10266-4721	4.7K 5%	D3
R22	A10266-4741	470K 5%	D3
R23	A10266-4741	470K 5%	C4
R24	A10266-2221	2.2K 5%	C5
R25	A10266-1812	180 5% .5W	H4
R26	A10266-3602	36 5% .5W	H4
R27	A10266-3021	3K 5%	D1
S2	C 7325-1	DPDT	C2
U1	C 4345-2	LM339	C4
U1X	C 3450-1	14 Pin Socket	C4
U2	C 5095-2	MC7815CT	E2
U3	C 5096-0	MC7915CT	E5
U4	C 7665-0	MOC3011	F4
X10	C 7817-7	.25 Tab	H1
X11	C 7817-7	.25 Tab	H1
X12	C 7817-7	.25 Tab	I1
X13	C 7817-7	.25 Tab	I1
PC Board	D 8165A7	REF Control	

8 Module Information

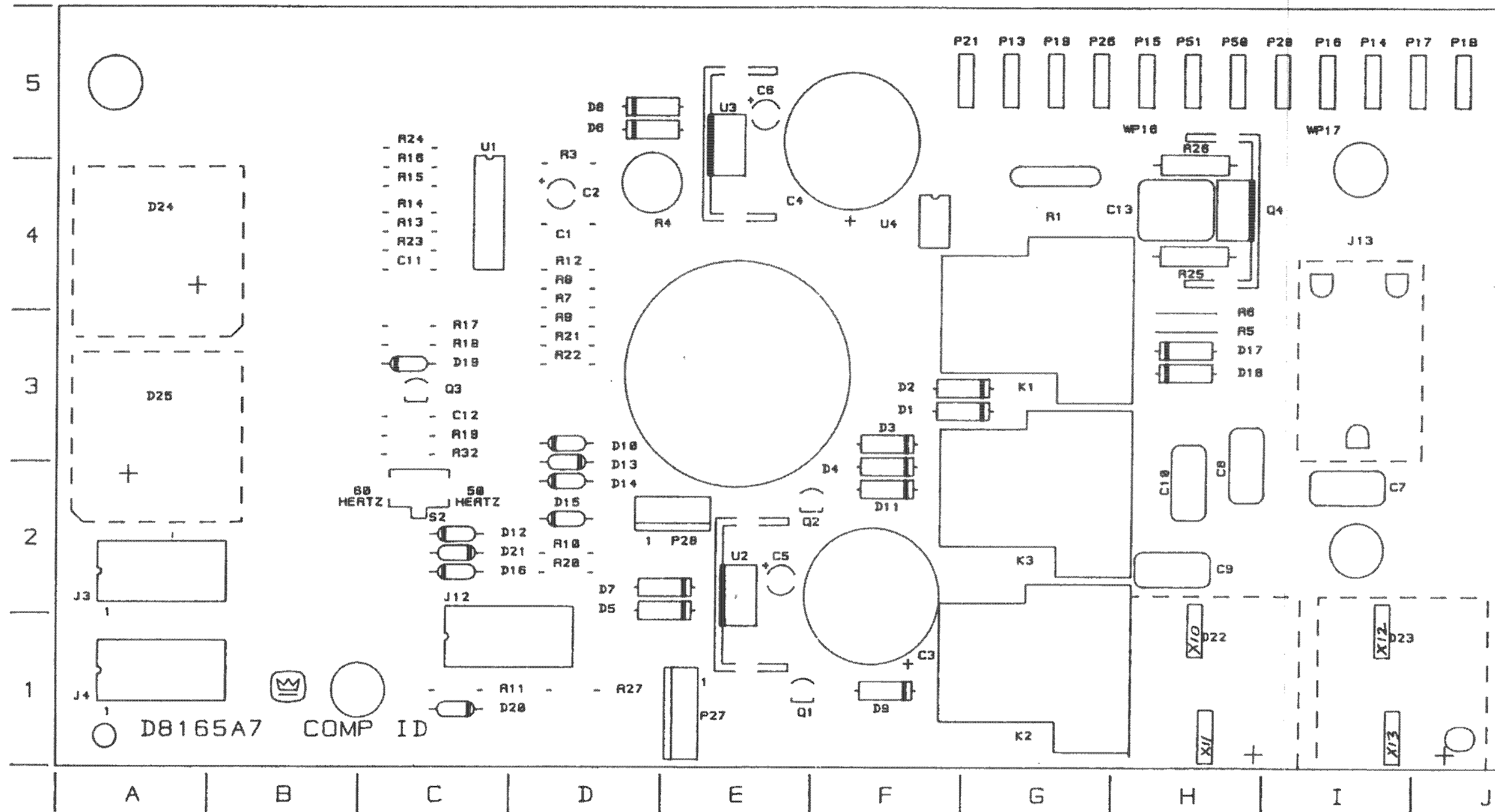

Figure 8.3 Q43183A3 Control Module Map

8 Module Information

8.7 Q43450-8 Control Module Parts List

<u>Cir. Des.</u>	<u>C.P.N.</u>	<u>Description</u>	<u>Map Loc</u>
C1	C 6804-6	.1μF 50V	D4
C2	C 6096-9	3.3μF 50V	D4
C3	C 7819-3	1800μF 35V	F1
C4	C 7819-3	1800μF 35V	F5
C5	C 5362-6	2.2μF 50V	E2
C6	C 5362-6	2.2μF 50V	E5
C7	C 9943-9	.1μF 250V	I2
C8	C 9943-9	.1μF 250V	H2
C9	C 9943-9	.1μF 250V	H2
C10	C 9943-9	.1μF 250V	I2
C11	C 6804-6	.1μF 50V	C4
C12	C 6804-6	.1μF 50V	C3
C13	C 8963-8	.47μF 250V	H4

D1	C 2851-1	1N4004	F3
D2	C 2851-1	1N4004	F3
D3	C 2851-1	1N4004	F3
D4	C 2851-1	1N4004	F2
D5	C 2851-1	1N4004	E2
D6	C 2851-1	1N4004	E5
D7	C 2851-1	1N4004	E2
D8	C 2851-1	1N4004	E5
D9	C 2851-1	1N4004	F1
D10	C 3181-2	1N4148	D3
D11	C 2851-1	1N4004	F2
D12	C 3181-2	1N4148	C2
D13	C 3181-2	1N4148	D2
D14	C 3181-2	1N4148	D2
D15	C 3181-2	1N4148	D2
D16	C 3181-2	1N4148	C2
D17	C 2851-1	1N4004	H3
D18	C 2851-1	1N4004	H3
D19	C 3549-0	1N961B, 10V	C3
D20	C 3181-2	1N4148	C1
D21	C 3181-2	1N4148	C2
D22*	C10437-9	Bridge Rect.	H1
D23*	C10437-9	Bridge Rect.	I1
D24*	C10437-9	Bridge Rect.	A3
D25*	C10437-9	Bridge Rect.	A4

*Not included with module, order separately.

HW1	A10086-10605	6-32X.3125	A4
HW2	A10086-10605	6-32X.3125	E2
HW3	A10086-10605	6-32X.3125	E5
HW5	A10094-4	#6 Lockwasher	A4
HW6	A10094-4	#6 Lockwasher	E2
HW7	A10094-4	#6 Lockwasher	E5
HW10	A10102-5	6-32 Hex Nut	A4

HW11	A10102-5	6-32 Hex Nut	E2
HW12	A10102-5	6-32 Hex Nut	E5
HW14	C 6510-9	T0220 HTSNK	A4
HW15	C 6510-9	T0220 HTSNK	E2
HW16	C 6510-9	T0220 HTSNK	E5
HW18	C 6541-4	T0220 Spreader	A4
HW19	C 6541-4	T0220 Spreader	E2
HW20	C 6541-4	T0220 Spreader	E5
HW25	H43267-6	Wires	H5 & I5
HW28	C 8982-8	Holder	G4

J3	C 4508-5	16 Pin Socket	A2
J4	C 4508-5	16 Pin Socket	A1
J12	C 4508-5	16 Pin Socket	C1
J13	C 9442-2	15 Pin Conn.	I4
J29	---	Not Used ---	B2

K1	C 9787-0	30A 24V Relay	G3
K2	C 9787-0	30A 24V Relay	G1
K3	C 9787-0	30A 24V Relay	G2

P13	C 7817-7	.25 Tab	F5
P14	C 7817-7	.25 Tab	I5
P15	C 7817-7	.25 Tab	H5
P16	C 7817-7	.25 Tab	I5
P17	C 7817-7	.25 Tab	I5
P18	C 7817-7	.25 Tab	J5
P19	C 7817-7	.25 Tab	G5
P20	C 7817-7	.25 Tab	I5
P21	C 7817-7	.25 Tab	G5
P26	C 7817-7	.25 Tab	G5
P27	C 7593-4	5 Pin Header	E1
P28	C 7592-6	4 Pin Header	D2
P50	C 7817-7	.25 Tab	H5
P51	C 7817-7	.25 Tab	H5

Q1	C 3625-8	2N4125	E1
Q2	C 3625-8	2N4125	E2
Q3	C 3625-8	2N4125	C3
Q4	C 7662-7	MAC218	H4

R1	C 8960-4	5 Ohm PTC	G4
R3	A10265-82521	82.5K 1%	D4
R4	C 3093-9	10K Helitrim	D4
R5	A10265-10031	100K 1%	H3
R6	A10265-10031	100K 1%	H4
R7	A10266-3331	33K 5%	D4
R8	---	Not Used ---	D4
R9	A10266-3921	3.9K 5%	D3
R10	A10266-2221	2.2K 5%	D2
R11	A10266-2221	2.2K 5%	C1
R12	A10266-4731	47K 5%	D4

8 Module Information

R13	A10266-2031	20K 5%	C4
R14	A10266-4731	47K 5%	C4
R15	A10266-1021	1K 5%	C4
R16	A10266-4731	47K 5%	C4
R17	A10266-3321	3.3K 5%	C3
R18	A10266-1231	12K 5%	C3
R19	A10265-11031	110K 1%	C3
R20	A10266-4721	4.7K 5%	D2
R21	A10266-4721	4.7K 5%	D3
R22	A10266-4741	470K 5%	D3
R23	A10266-4741	470K 5%	C4
R24	A10266-2221	2.2K 5%	C5
R25	A10266-1812	180 5% .5W	H4
R26	A10266-3602	36 5% .5W	H4
R27	A10266-3021	3K 5%	D1
S2	C 7325-1	DPDT	C2
U1	C 4345-2	LM339	C4
U1X	C 3450-1	14 Pin Socket	C4
U2	C 5095-2	MC7815CT	E2
U3	C 5096-0	MC7915CT	E5
U4	C 7665-0	MOC3011	F4
X10	C 7817-7	.25 Tab	H1
X11	C 7817-7	.25 Tab	H1
X12	C 7817-7	.25 Tab	I1
X13	C 7817-7	.25 Tab	I1
PC Board	D 8853-0	REF Control #2	

8 Module Information

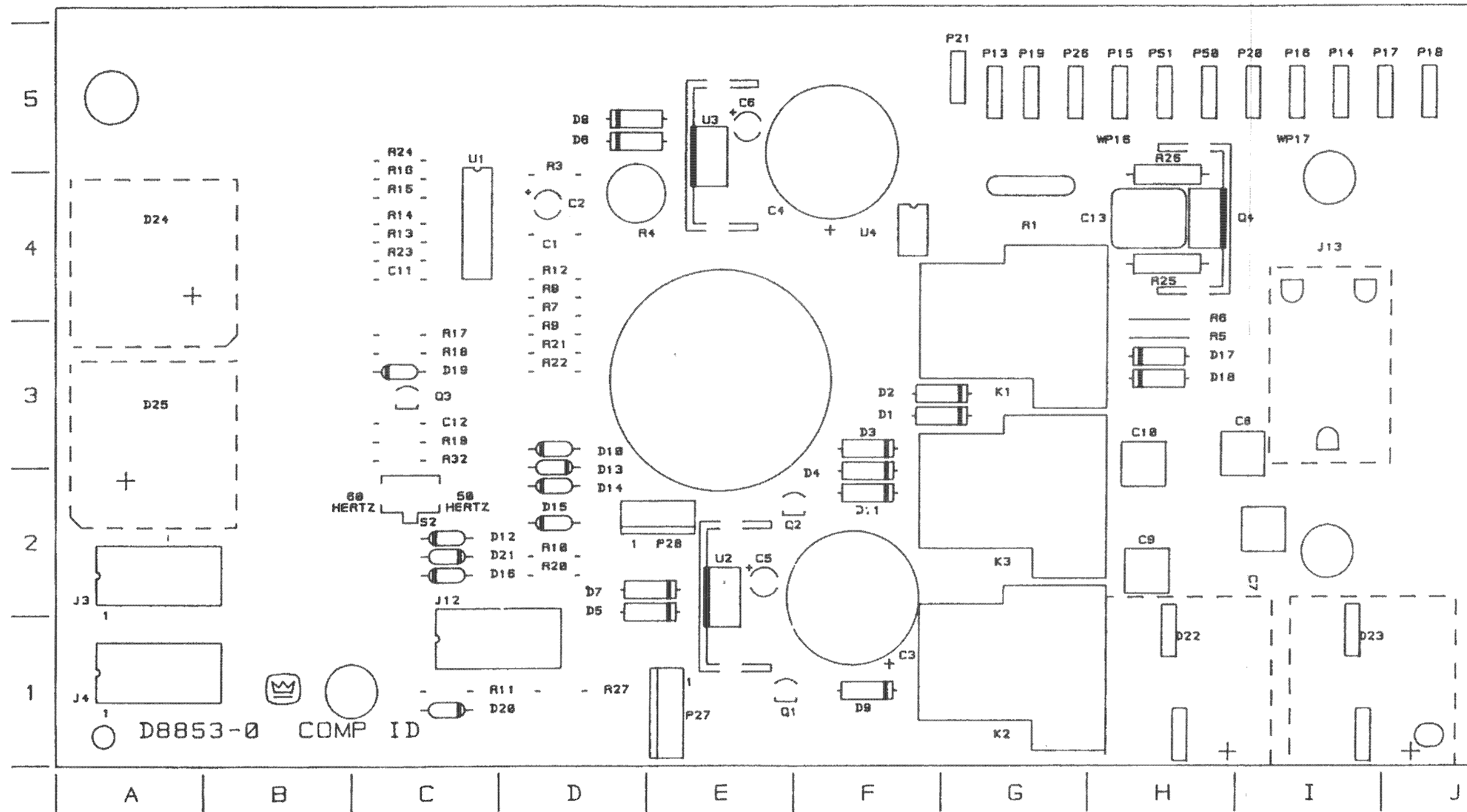

Figure 8.4 Q43450-8 Control Module Map

8 Module Information

8.8 Q43504-2 Control Module Parts List

<u>Cir. Des.</u>	<u>C.P.N.</u>	<u>Description</u>	<u>Map Loc</u>				
C1	C 6804-6	.1 μ F 50V	D4	HW1	A10086-10605	6-32X.3125	E2
C2	C 6096-9	3.3 μ F 50V	D4	HW2	C 6541-4	Torq. Spreader	E2
C3	C 7819-3	1800 μ F 35V	F2	HW3	A10094-4	#6 Lockwasher	E2
C4	C 7819-3	1800 μ F 35V	F5	HW4	A10102-5	6-32 Nut	E2
C5	C 5362-6	2.2 μ F 50V	E2	HW5	A10086-10605	6-32X.3125	E5
C6	C 5362-6	2.2 μ F 50V	E5	HW6	C 6541-4	Torq. Spreader	E5
C7	C 9943-9	.1 μ F 250V	I2	HW7	A10094-4	#6 Lockwasher	E5
C8	C 9943-9	.1 μ F 250V	J2	HW8	A10102-5	6-32 Nut	E5
C9	C 8554-5	.22 μ F 250V	H2	HW9	A10086-10605	6-32X.3125	G5
C10	C 8554-5	.22 μ F 250V	J2	HW10	C 6541-4	Torq. Spreader	G5
C11	C 6804-6	.1 μ F 50V	C4	HW11	A10094-4	#6 Lockwasher	G5
C12	C 6804-6	.1 μ F 50V	C3	HW12	A10102-5	6-32 Hex Nut	G5
C13	C 8963-8	.47 μ F 250V	G5	HW13	H43267-6	Wires	I5
C14	C10326-4	.1 μ F 250V	J5	J3	C 4508-5	16 Pin Socket	A2
C15	C10325-6	2200pF 250V	H5	J4	C 4508-5	16 Pin Socket	A1
C16	C10325-6	2200pF 250V	H5	J12	C 4508-5	16 Pin Socket	C1
C17	C 8554-5	.22 μ F 250V	H2	J13	C 8537-0	6 Pin Header	I4
C18	C 8554-5	.22 μ F 250V	J2	J14	c10304-1	9 Pos Header	I3
D1	C 2851-1	1N4004	G3	K1	C10304-1	30A 24V Relay	G4
D2	C 2851-1	1N4004	F3	K2	C10304-1	30A 24V Relay	G1
D3	C 2851-1	1N4004	F3	K3	C10304-1	30A 24V Relay	G2
D4	C 2851-1	1N4004	F2	L1	H43598-4	Choke	I5
D5	C 2851-1	1N4004	E2	P13	C 7817-7	.25 Tab	H4
D6	C 2851-1	1N4004	D5	P14	C 7817-7	.25 Tab	I4
D7	C 2851-1	1N4004	E2	P15	C 7817-7	.25 Tab	I4
D8	C 2851-1	1N4004	D5	P16	C 7817-7	.25 Tab	I4
D9	C 2851-1	1N4004	F1	P17	C 7817-7	.25 Tab	J4
D10	C 3181-2	1N4148	D3	P18	C 7817-7	.25 Tab	J4
D11	C 2851-1	1N4004	F2	P19	C 7817-7	.25 Tab	J5
D12	C 3181-2	1N4148	C2	P20	C 7817-7	.25 Tab	I4
D13	C 3181-2	1N4148	D3	P21	C 7817-7	.25 Tab	G6
D14	C 3181-2	1N4148	D2	P26	C 7817-7	.25 Tab	H4
D15	C 3181-2	1N4148	D2	P27	C 7593-4	5 Pin Header	E1
D16	C 3181-2	1N4148	C2	P28	C 7592-6	4 Pin Header	D2
D17	C 2851-1	1N4004	G3	P50	C 7817-7	.25 Tab	H6
D18	C 2851-1	1N4004	F3	P51	C 7817-7	.25 Tab	H6
D19	C 3549-0	1N961B, 10V	C3	Q1	C 3625-8	2N4125	E1
D20	C 3181-2	1N4148	C1	Q2	C 3625-8	2N4125	E2
D21	C 3181-2	1N4148	C2	Q3	C 3625-8	2N4125	C3
D22*	C10437-9	Bridge Rect.	H1	Q4	C 7662-7	MAC218	G5
D22X	C 7817-7	.25 Tab	H1	Q4X	C 6510-9	Heatsink	G5
D22XX	C 7817-7	.25 Tab	H1	R1	C 8960-4	5 Ohm PTC	H4
D23*	C10437-9	Bridge Rect.	I1	R1X	C 8982-8	Plastic Holder	H4
D23X	C 7817-7	.25 Tab	I1	R3	A10265-82521	82.5K 1%	D4
D23XX	C 7817-7	.25 Tab	I1	R4	C 3093-9	10K Helitrim	D4
D24*	C10437-9	Bridge Rect.	A4	R5	A10265-10031	100K 1%	F4
D25*	C10437-9	Bridge Rect.	A3				

*Not included with module, order separately.

8 Module Information

R6	A10265-10031	100K 1%	F4
R7	A10266-3331	33K 5%	D4
R8	--- Not Used ---		D4
R9	A10266-3921	3.9K 5%	D3
R10	A10266-2221	2.2K 5%	D2
R11	A10266-2221	2.2K 5%	C1
R12	A10266-4731	47K 5%	D4
R13	A10266-2031	20K 5%	C4
R14	A10266-4731	47K 5%	C4
R15	A10266-1021	1K 5%	C4
R16	A10266-4731	47K 5%	C4
R17	A10266-3321	3.3K 5%	C3
R18	A10266-1231	12K 5%	C3
R19	A10265-11031	110K 1%	C3
R20	A10266-4721	4.7K 5%	D2
R21	A10266-4721	4.7K 5%	D3
R22	A10266-4741	470K 5%	D3
R23	A10266-4741	470K 5%	C4
R24	A10266-2221	2.2K 5%	C5
R25	A10266-1812	180 5% .5W	G5
R26	A10266-3602	36 5% .5W	G6
R27	A10266-3021	3K 5%	D1
R32	A10266-5141	510K 5%	C3
S2	C 7325-1	DPDT	C2
U1	C 4345-2	LM339	C4
U1X	C 3450-1	14 Pin Socket	C4
U2	C 5095-2	MC7815CT	E2
U2X	C 6510-9	Heatsink	E2
U3	C 5096-0	MC7915CT	E5
U3X	C 6510-9	Heatsink	E5
U4	C 7665-0	MOC3011	F4
1	D 9099-9	REF Control Board	

8 Module Information

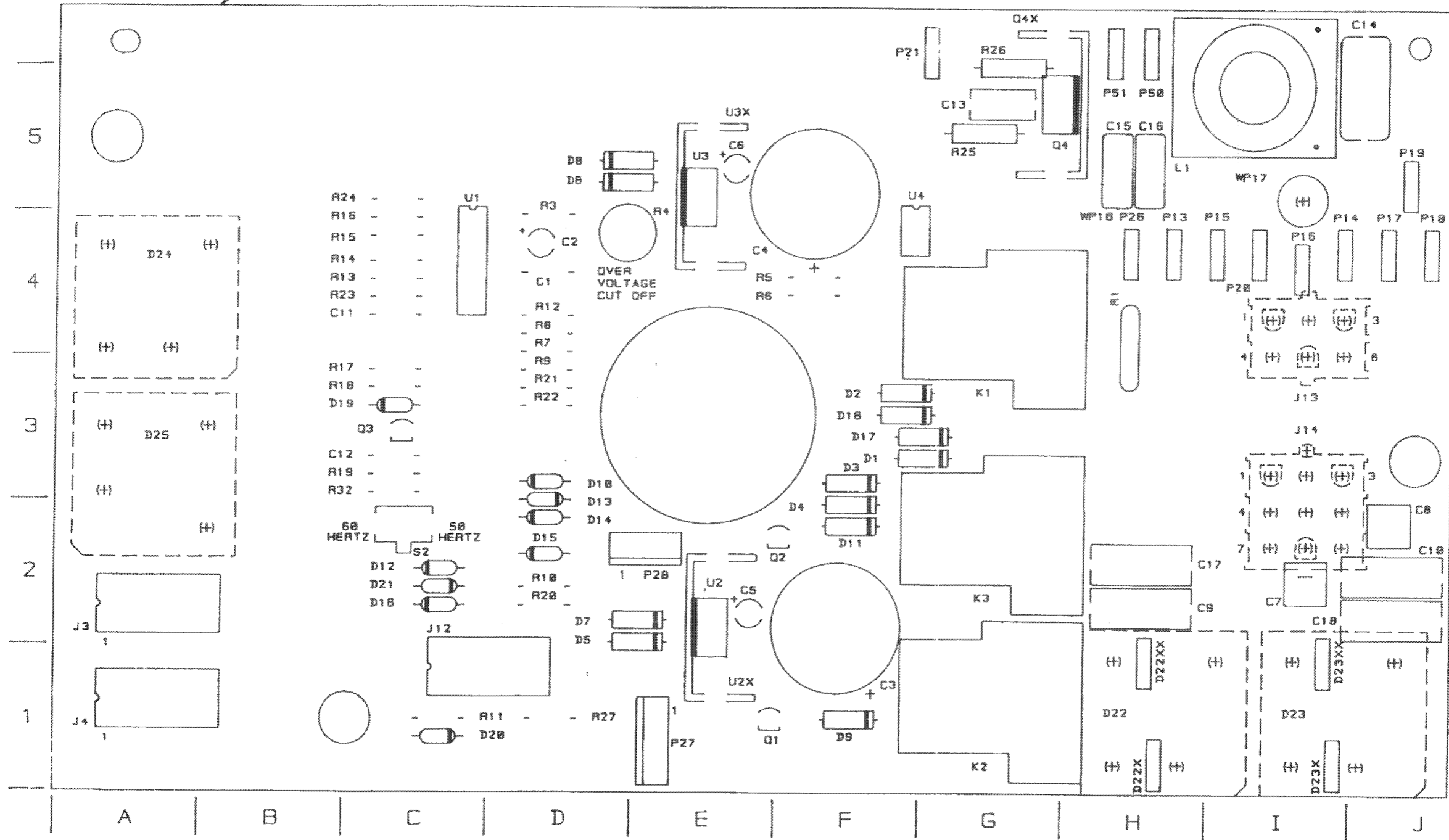

Figure 8.5 Q43504-2 Control Module Map

8 Module Information

8.9 Q43018-3 Display Module Parts List

<u>Cir. Des.</u>	<u>C.P.N.</u>	<u>Description</u>	<u>Map Loc</u>				
C1	C 6813-7	27pF 200V	B2	E8	C10592-1	Green LED	K1
C2	C 6813-7	27pF 200V	B1	E9	C10592-1	Green LED	J1
C3	C 6802-0	.47μF 50V	B3	E10	C10592-1	Green LED	L1
C4	C 6802-0	.47μF 50V	B2	E11	C10592-1	Green LED	I1
C5	C 6804-6	.1μF 50V	E2	E12	C10592-1	Green LED	L1
C6	C 6804-6	.1μF 50V	E2	E13	C10592-1	Green LED	I1
C7	C 6804-6	.1μF 50V	E2	E14	C10592-1	Green LED	L1
C8	C 6804-6	.1μF 50V	E2	E15	C10592-1	Green LED	I2
C9	C 6804-6	.1μF 50V	E2	E16	C10592-1	Green LED	L2
C10	C 6804-6	.1μF 50V	E1	E17	C 4342-9	Amber LED	N2
C11	C 6804-6	.1μF 50V	C3	J3	D 6990-2	16 pin cable	D2
C12	C 6804-6	.1μF 50V	C2	P12	D 6990-2	16 pin cable	F2
C13	C 6804-6	.1μF 50V	C3	Q1	C 3625-8	2N4125	J2
C14	C 6804-6	.1μF 50V	C1	Q2	C 3625-8	2N4125	L2
C15	C 6802-0	.47μF 50V	A3	R1	A10265-10031	100K 1%	A2
C16	C 6802-0	.47μF 50V	A1	R2	A10265-10031	100K 1%	A1
C17	C 6807-9	.001μF 100V	C2	R7	A10265-10031	100K 1%	A2
C18	C 6807-9	.001μF 100V	C2	R8	A10265-10031	100K 1%	A1
C19	C 6807-9	.001μF 100V	E2	R9	A10265-10021	10K 1%	A2
C20	C 6807-9	.001μF 100V	E2	R10	A10265-10021	10K 1%	A1
C21	C 6807-9	.001μF 100V	E2	R11	A10265-49911	4.99K 1%	B2
C22	C 6807-9	.001μF 100V	E1	R12	A10265-49911	4.99K 1%	A1
C23	C 6807-9	.001μF 100V	E1	R13	A10265-82511	8.25K 1%	C2
C24	C 6807-9	.001μF 100V	E1	R15	A10265-14321	14.3K 1%	C2
C25	C 6807-9	.001μF 100V	C1	R17	A10265-82511	8.25K 1%	C2
C26	C 6807-9	.001μF 100V	C1	R19	A10266-8211	820 5%	J2
C27	C 6804-6	.1μF 50V	K2	R20	A10266-8211	820 5%	L2
C28	C 6804-6	.1μF 50V	L2	R21	A10265-10021	10K 1%	B2
D1	C 3181-2	1N4148	A2	R22	A10265-10021	10K 1%	B1
D2	C 3181-2	1N4148	A1	R23	A10266-5121	5.1K 5%	B3
D3	C 3181-2	1N4148	A2	R24	A10266-5121	5.1K 5%	B2
D4	C 3181-2	1N4148	A1	R25	A10266-8211	820 5%	K2
D5	C 3181-2	1N4148	G2	R26	A10266-8211	820 5%	L2
D6	C 3181-2	1N4148	M1	R27	A10266-1851	1.8M 5%	B2
D7	C 3181-2	1N4148	I2	R28	A10266-1851	1.8M 5%	B1
D8	C 3181-2	1N4148	L2	R29	A10265-68111	6.81K 1%	D2
D9	C 3181-2	1N4148	B2	R30	A10265-68111	6.81K 1%	E1
D10	C 3181-2	1N4148	B1	R31	A10265-16911	1.69K 1%	D2
D11	C 3181-2	1N4148	J2	R32	A10265-16911	1.69K 1%	E1
D12	C 3181-2	1N4148	L2	R33	A10265-95301	953 1%	D2
E1	C 4431-0	Yellow LED	I2	R34	A10265-95301	953 1%	D1
E2	C 4431-0	Yellow LED	L2	R35	A10265-53601	563 1%	D2
E3	C10592-1	Green LED	J2	R36	A10265-53601	536 1%	D1
E4	C10592-1	Green LED	L2	R37	A10266-3011	300 5%	D2
E5	C10592-1	Green LED	J1	R38	A10266-3011	300 5%	D1
E6	C10592-1	Green LED	K1	R39	A10266-3911	390 5%	D2
E7	C10592-1	Green LED	J1	R40	A10266-3911	390 5%	D1
				R41	A10266-2231	22K 5%	B2

8 Module Information

R42	A10266-2231	22K 5%	C1	R71	A10266-8211	820 5%	I2
R43	A10266-2231	22K 5%	C2	R72	A10266-8211	820 5%	M1
R44	A10266-2231	22K 5%	B1	R73	A10266-1821	1.8K 5%	I2
R45	A10266-2231	22K 5%	E2	R74	A10266-1821	1.8K 5%	M1
R46	A10266-2231	22K 5%	E1	R75	A10266-3321	3.3K 5%	I2
R47	A10266-2231	22K 5%	E2	R76	A10266-3321	3.3K 5%	L1
R48	A10266-2231	22K 5%	E1	R77	A10266-2031	20K 5%	G1
R49	A10266-2231	22K 5%	E2	R78	C 3670-4	5K Pot	G1
R50	A10266-2231	22K 5%	E1	R79	A10266-4741	470K 5%	K2
R51	A10266-3911	390 5%	K2	R80	A10266-4741	470K 5%	L1
R52	A10266-3911	390 5%	K1	R81	A10266-1521	1.5K 5%	I2
R53	A10266-3911	390 5%	K2	R82	A10266-1521	1.5K 5%	L2
R54	A10266-3911	390 5%	K1	S1	C 7325-1	DPDT	G1
R55	A10266-3911	390 5%	K2	S2	C 7325-1	DPDT	F1
R56	A10266-3911	390 5%	L1	U1	C 7558-7	MC33079	B2
R57	A10266-3911	390 5%	J2	U2	C 7558-7	MC33079	B1
R58	A10266-3911	390 5%	L1	U3	C 4345-2	LM339	C2
R59	A10266-3911	390 5%	J2	U4	C 4345-2	LM339	C1
R60	A10266-3911	390 5%	L1	U5	C 4345-2	LM339	F2
R61	A10266-1051	1M 5%	E2	U6	C 4345-2	LM339	F1
R62	A10266-1051	1M 5%	D1	Z1	---	Not Used ---	G1
R63	A10266-3351	3.3M 5%	E2	Z2	---	Not Used ---	G1
R64	A10266-3351	3.3M 5%	D1	1	D 7940-6	Display Board	
R66	A10266-4731	47K 5%	F1				
R68	A10266-1021	1K 5%	F1				
R69	A10266-5151	5.1M 5%	A2				
R70	A10266-5151	5.1M 5%	A1				

8 Module Information

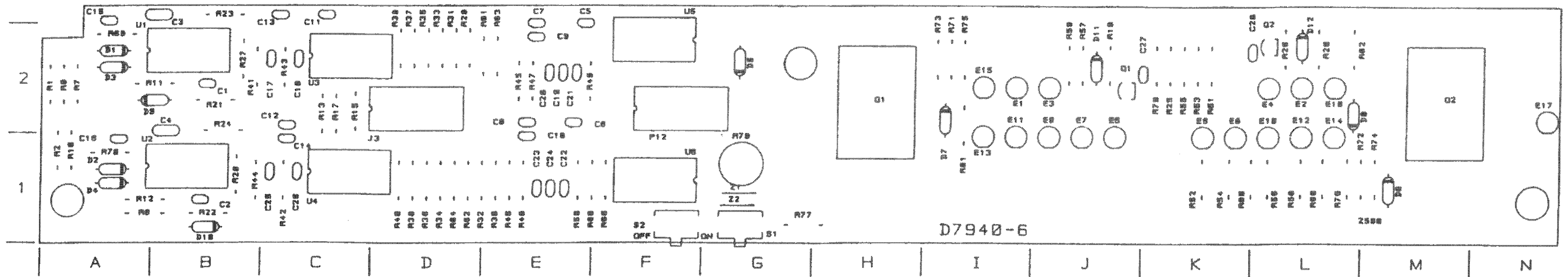

Figure 8.6 Q43018-3 Display Module Map

8 Module Information

8.10 Q43311-2 Main Module Parts List

<u>Cir. Des.</u>	<u>C.P.N.</u>	<u>Description</u>	<u>Map Loc</u>	C150/250	--- Not Used ---	O5/D5
C1	C 5362-6	2.2µF 50V	I4	C151/251	C 6806-1	L5/A5
C2	C 3913-8	470µF 35V	G4	C152/252	C 6811-1	N4/C4
C4	C 6802-0	.47µF 50V	I5	C153/253	C 6804-6	J2/F2
C7	C 6804-6	.1µF 35V	C2	C154/254	C 8426-6	M5/B5
C100/200	C 8576-8	100µF 35V	J2/F2	C155/255	C 6804-6	K2/E2
C101/201	C 8338-3	47pF 300V	J3/F3	C156/256	C 6804-6	N1/A1
C102/202	C 8576-8	100µF 35V	J5/F5	C157/257	C 6813-7	J3/F3
C103/203	C 6805-3	.022µF 100V	I3/F3	C159/259	C 8551-1	H2/G2
C104/204	C 6805-3	.022µF 100V	J3/G3	C160/260	C 6811-1	M4/A4
C105/205	C 6813-7	27pF 200V	M3/A3	D1	C 2851-1	H4
C106/206	C 6813-7	27pF 200V	N3/C3	D2	C 2851-1	H4
C107/207	C 7870-6	.33µF 63V	I5/G5	D3	C 2851-1	I4
C108/208	C 6813-7	27pF 200V	M4/B4	D4	C 2851-1	H4
C109/209	C 8576-8	100µF 35V	K5/E5	D5	C 2851-1	H4
C110/210	C 5362-6	2.2µF 50V	J5/F5	D6	C 2851-1	G4
C111/211	C 6807-9	.001µF 100V	I3/F3	D7	C 2851-1	G4
C112/212	C 8990-1	.18µF 63V	N2/B2	D100/200	C 3181-2	J5/F5
C113/213	C 8989-3	6.8µF 50V	M2/B2	D101/201	C 3181-2	J6/F6
C114/214	C 8576-8	100µF 35V	N2/B2	D108/208	C 3181-2	I3/F3
C115/215	C 8576-8	100µF 35V	M2/B2	D109/209	C 3181-2	N4/C4
C116/216	C 8989-3	6.8µF 50V	M2/B2	D110/210	C 3181-2	M4/A4
C117/217	C 8990-1	.18µF 63V	M1/B1	D111/211	--- Not Used ---	M4/A4
C118/218	C 6813-7	27pF 200V	N1/B1	D112/212	C 3181-2	M3/B3
C119/219	C 6802-0	.47µF 50V	M4/B4	D113/213	C 3181-2	M3/B3
C120/220	C 6804-6	.1µF 50V	J5/E5	D114/214	C 8158-5	N3/C3
C121/221	C 6804-6	.1µF 50V	O4/D4	D115/215	C 8158-5	M3/A3
C122/222	C 5194-3	68pF Disc	L4/A4	D119/219	C 3181-2	O4/D4
C123/223	C 6808-7	470pF 100V	O4/D5	D120/220	C 3181-2	L4/A4
C124/224	C 5194-3	68pF Disc	J3/F3	D121/221	C 3824-7	J4/F4
C129/229	C 6812-9	47pF 100V	L5/A4	D122/222	C 3181-2	J3/F3
C130/230	C 6814-5	12pF 200V	I3/G3	D123/223	--- Not Used ---	N4/C4
C131/231	C 6814-5	12pF 200V	I3/G3	D124/224	C 3181-2	K3/E3
C132/232	C 6806-1	.01µF 100V	L3/D3	D125/225	C 3181-2	K4/E4
C133/233	C 6813-7	27pF 200V	H2/G2	D126/226	C 8158-5	L4/A4
C134/234	C 6805-3	.022µF 100V	N2/A2	D127/227	C 8158-5	O4/D4
C135/235	C 6805-3	.022µF 100V	L3/D3	D128/228	C 3181-2	J5/F5
C136/236	C 6808-7	470pF 100V	O2/A2	D129/229	--- Not Used ---	L3/C3
C137/237	C 6808-7	470pF 100V	L2/D2	D130/230	C 3181-2	O4/D4
C138/238	C 6812-9	47pF 100V	I3/G3	D131/231	C 3181-2	N4/C4
C139/239	C 6812-9	47pF 100V	I3/G3	D132/232	C 3181-2	M4/A4
C140/240	C 6814-5	12pF 200V	M3/B3	D133/233	C 3181-2	L4/A4
C141/241	C 6814-5	12pF 200V	M3/B3	E100/200	C 9857-1	J5/F5
C143/243	C 6808-7	470pF 100V	N4/C4	E101/201	C 9857-1	J6/F6
C144/244	C 8576-8	100µF 35V	I2/G2	HW16	C 1811-6	O5
C145/245	C 6812-9	47pF 100V	I2/F2	HW17	C 1811-6	N5
C146/246	C 6812-9	47pF 100V	K4/E4	HW18	C 1811-6	B5
C147/247	--- Not Used ---		N3/C3	HW19	C 1811-6	A5
C148/248	C 6808-7	470pF 100V	M4/A4			
C149/249	C 6807-9	.001µF 100V	M4/B4			

8 Module Information

J2	C 4508-5	16 Pin IC Skt.	H4	R1	A10265-10021	10K 1%	E2
J100/200	C 8432-4	3 Cond Ph Jk	11/G1	R4	A10265-10521	10.5K 1%	D1
J100X/200XC	C 6778-2	Ph Jk Cover	11/G1	R7	A10266-4331	43K 5%	I6
J500	D 8395-2	7.75" 12pin Cbl	O5	R8	A10265-75021	75K 1%	H6
J600	D 8397-8	2.5" 12pin Cbl	N5	R10	--- Not Used ---		C2
J700	D 8397-8	2.5" 12pin Cbl	B5	R17	A10265-75021	75K 1%	H6
J800	D 8395-2	7.75" 12pin Cbl	A5	R18	A10266-4331	43K 5%	G6
				R19	A10266-2R72	2.7 5% .5W	I4
N101/201	D 7946-3	Res Net-ODEP	M2/C2	R100/200	--- Not Used ---		I3/G3
N102/202	D 6082-8	Res Net-C	J4/F4	R101/201	A10265-10211	1.02K 1%	J2/F2
				R102/202	A10266-5111	510 5%	K4/E4
P1	C 7593-4	5pos Header	H2	R103/203	A10265-20523	20.5K 1% 1W	J3/F3
P6	C 8418-3	3pos Header	H2	R104/204	A10265-26711	2.67K 1%	M3/A3
P11	C 7593-4	5pos Header	H5	R105/205	A10265-26711	2.67K 1%	N3/C3
P101/201	C 7592-6	4pos Header	J1/F1	R106/206	A10265-11821	11.8K 1%	L3/A3
				R107/207	A10266-6831	68K 5%	M3/A3
Q100/200	D 2961-7	2961	N3/C3	R108/208	A10266-8211	820 5%	N4/C4
Q101/201	C 8104-9	MPSW92	M3/B3	R109/209	A10266-9101	91 5%	N4/C4
Q102/202	C 8103-1	MPSW42	N3/C3	R110/210	A10266-6831	68K 5%	N3/C3
Q103/203	C 3625-8	2N4125	M3/B3	R111/211	A10265-11821	11.8 1%	O3/D3
Q104/204	C 8104-9	MPSW92	N4/C4	R112/212	A10265-49921	49.9K 1%	H3/G3
Q105/205	C 8104-9	MPSW92	N4/C4	R113/213	A10265-48711	4.87K 1%	I4/F4
Q106/206	C 3625-8	2N4125	O3/A3	R114/214	A10266-1521	1.5K 5%	I4/G4
Q107/207	C 3786-8	MPS4250A	M4/B4	R115/215	A10266-5141	510K 5%	L2/C2
Q108/208	C 5891-4	MTS105 Therm	N4/C4	R116/216	A10266-3351	3.3M 5%	I4/G4
Q109/209	D 2961-7	2961	K3/E3	R117/217	A10266-4731	47K 5%	H3/G3
Q110/210	C 8103-1	MPSW42	M4/B4	R118/218	A10265-68101	681 1%	M4/B4
Q111/211	C 8103-1	MPSW42	M4/B4	R119/219	A10265-12111	1.21K 1%	N5/C5
Q112/212	C 3625-8	2N4125	J4/E4	R120/220	A10265-68101	681 1%	M4/B4
Q113/213	C 3625-8	2N4125	J4/F4	R121/221	C 5062-2	100K LIN POT	O1/A1
Q114/214	C 7458-0	2N4123	K3/E3	R122/222	A10266-2741	270K 5%	N2/A2
Q115/215	D 2962-5	MPSA18	O5/D5	R123/223	A10266-2032	20K 5% .5W	O2/A2
Q116/216	C 3786-8	MPS4250A	L5/A5	R124/224	A10266-6821	6.8K 5%	O1/A1
Q117/217	D 2961-7	2961	O3/A3	R125/225	A10266-1011	100 5%	O2/A2
Q118/218	D 2961-7	2961	O3/A3	R126/226	A10266-1011	100 5%	O2/A2
Q119/219	C 3625-8	2N4125	K3/E3	R127/227	A10266-6821	6.8K 5%	N3/A3
Q120/220	C 3625-8	2N4123	K3/E3	R128/228	A10266-1331	13K 5%	N2/A2
Q121/221	C 7458-0	2N4123	O4/D4	R129/229	A10266-1041	100K 5%	N3/A3
Q122/222	C 3625-8	2N4125	L3/A3	R130/230	A10266-1041	100K 5%	L3/D3
Q123/223	C 3625-8	2N4125	K4/E4	R131/231	A10266-1331	13K 5%	L3/D3
Q124/224	--- Not Used ---		M5/B5	R132/232	C 5062-2	100K LIN POT	K1/E1
Q125/225	--- Not Used ---		N5/C5	R133/233	A10266-2741	270K 5%	K2/E2
Q126/226	C 3625-8	2N4125	K6/E6	R134/234	A10266-2032	20K 5% .5W	K2/D2
Q127/227	C 7458-0	2N4123	K5/E5	R135/235	A10266-1011	100 5%	K2/D2
Q128/228	C 3625-8	2N4125	K5/E5	R136/236	A10266-6821	6.8K 5%	L2/D2
Q129/229	C 7458-0	2N4123	K5/E5	R137/237	A10266-1011	100 5%	K2/D2
Q130/230	C 3625-8	2N4125	K5/E5	R138/238	A10266-6821	6.8K 5%	L3/C3
Q131/231	C 3625-8	2N4125	L3/D3	R139/239	A10266-8211	820 5%	M4/A4
Q132/232	C 3625-8	2N4125	K3/D3	R140/240	A10266-9101	91 5%	M4/A4
Q133/233	C 3625-8	2N4125	O4/D4	R141/241	A10266-1541	150K 5%	N3/A3
Q134/234	C 7458-0	2N4123	L3/A3	R142/242	A10266-1541	150K 5%	L3/D3
				R143/243	A10266-4711	470 5%	K6/D6

8 Module Information

R144/244	A10266-4711	470 5%	K5/D5	R197/297	A10265-10021	10K 1%	K4/E4
R145/245	A10266-4711	470 5%	J6/E5	R198/298	A10266-3921	3.9K 5%	K3/E3
R146/246	A10265-11821	11.8K 1%	O4/D4	R199/299	A10265-10021	10K 1%	K3/E3
R147/247	C 5868-2	0 OHM	O5/D5	R500/600	A10266-3041	300K 5%	I3/F3
R148/248	A10265-20011	2K 1%	N4/C4	R501/601	A10266-3041	300K 5%	J3/F3
R149/249	A10266-1012	100 5% .5W	L5/A5	R502/602	A10266-3041	300K 5%	I3/F3
R150/250	A10265-20011	2K 1%	M4/A4	R503/603	A10266-4702	47 5% .5W	J2/F2
R151/251	A10265-11821	11.8K 1%	L4/A4	R504/604	A10266-1041	100K 5%	L2/C2
R152/252	A10265-11821	11.8K 1%	O2/A2	R505/605	A10266-1041	100K 5%	L2/C2
R153/253	A10124-24	#24 Buss Wire	I3/G3	R506/606	A10266-1521	1.5K 5%	J5/F5
R154/254	A10266-5601	56 5%	K5/D5	R507/607	A10266-4711	470 5%	J5/F5
R155/255	A10266-4731	47K 5%	I4/F4	R508/608	A10266-1041	100K 5%	J5/F5
R156/256	A10266-1321	1.3K 5%	N2/A2	R509/609	A10265-49911	4.99K 1%	I3/G3
R157/257	A10266-1321	1.3K 5%	L2/D2	R510/610	A10265-49911	4.99K 1%	H2/G2
R158/258	A10266-9121	9.1K 5%	K2/E2	R511/611	A10265-49911	4.99K 1%	H2/G2
R159/259	A10266-1331	13K 5%	J3/F3	R512/612	C 9079-2	200/220 Pot	H3/H3
R160/260	A10266-5601	56 5%	K5/D5	R513/613	A10265-49911	4.99K 1%	H3/G3
R161/261	A10266-4701	47 5%	M3/B3	R514/614	C 7340-0	24 5% 3W	H1/H1
R162/262	A10266-4701	47 5%	M3/B3	R515/615	A10266-1821	1.8K 5%	J2/F2
R163/263	A10266-5601	56 5%	K5/D5	R516/616	--- Not Used ---		L2/C2
R164/264	A10266-4711	470 5%	K5/D5	R517/617	A10266-9101	91 5%	M4/B4
R165/265	A10266-4711	470 5%	K5/D5	R518/618	A10266-9101	91 5%	M4/B4
R166/266	A10266-4711	470 5%	K4/D4	R519/619	A10265-12111	1.21K 1%	M5/A5
R167/267	A10265-10011	1K 1%	O2/A2	R520/620	--- Not Used ---		M5/A5
R168/268	A10265-95301	953 1%	O2/A2	R521/621	--- Not Used ---		M5/B5
R169/269	A10266-1041	100K 5%	N3/C3	R522/622	--- Not Used ---		M5/A5
R170/270	A10265-10011	1K 1%	K3/E3	R523/623	--- Not Used ---		N5/C5
R171/271	A10265-95301	953 1%	K3/E3	R524/624	--- Not Used ---		N5/C5
R172/272	A10266-1041	100K 5%	M3/A3	R525/625	--- Not Used ---		M5/B5
R173/273	A10266-5601	56 5%	K5/D5	R526/626	A10265-10021	10K 1%	I5/F5
R174/274	A10265-10721	10.7K 1%	I2/G2	R527/627	A10266-3921	3.9K 5%	L4/D4
R175/275	A10265-46411	4.64K 1%	H2/G2	R528/628	A10265-10021	10K 1%	L4/D4
R176/276	A10265-10721	10.7K 1%	J2/F2	R529/629	A10266-4731	47K 5%	L4/D4
R177/277	A10265-13021	13.0K 1%	H2/G2	R530/630	A10265-10021	10K 1%	O3/D4
R179/279	A10266-1321	1.3K 5%	K4/E4	R531/631	A10266-4731	47K 5%	L3/D3
R180/280	A10266-4711	470 5%	M3/A3	R532/632	A10265-10021	10K 1%	L4/A4
R181/281	A10265-48711	4.87K 1%	M4/B4	R533/633	A10265-10021	10K 1%	O3/D3
R182/282	A10266-2201	22 5%	J2/F2	R534/634	A10265-10021	10K 1%	L3/A3
R183/283	A10266-4731	47K 5%	O3/D3	R535/635	A10266-1R01	1 5%	O5/A5
R184/284	A10266-4741	470K 5%	K5/D5				
R185/285	A10266-4731	47K 5%	O4/D3	S2	C 7325-1	DPDT Switch	H1
R186/286	A10266-2751	2.7M 5%	J5/E5	S3	C 7960-5	3 Pos Switch	H2
R187/287	A10266-3321	3.3K 5%	J5/E5	S4	C 6781-6	6P3T Switch	C1
R188/288	A10266-3321	3.3K 5%	J6/E6				
R189/289	A10266-2731	27K 5%	J5/E5	TP1	C 6564-6	10P Header	L5
R190/290	A10266-2051	2M 5%	J5/F5	TP2	C 6564-6	10P Header	D5
R191/291	A10266-4731	47K 5%	L3/A3	TP3	C 7873-0	2P Header	F4
R192/292	A10266-4731	47K 5%	L3/A3	TP4	C 7873-0	2P Header	I4
R193/293	A10265-10021	10K 1%	J5/F5				
R194/294	A10265-20021	20K 1%	J2/F2	U1	C 5095-2	MC7815CT	H5
R195/295	A10266-4701	47 5%	J4/F4	U1X	C 9494-3	Heatsink	H5
R196/296	A10266-3921	3.9K 5%	K4/E4	U2	C 5096-0	MC7915CT	G5

8 Module Information

U2X	C 9494-3	Heasink	G5
U100/200	C 6911-9	UPA75	N2/B2
U101/201	C 6411-0	H11C2	J5/E5
U101X/201X	C 8019-9	6 pin IC Skt	J5/E5
U102/202	C 4345-2	LM339N	15/G5
U102X/202X	C 3450-1	14 pin IC Skt	15/G5
U103/203	C 6910-1	UPA76	L2/D2
U104/204	C 7558-7	MC33079P	13/F3
U104X/204X	C 3450-1	14 pin IC Skt	13/F3
Z01	--- Not Used ---		D1
Z02	--- Not Used ---		C1
Z03	--- Not Used ---		C1
Z04	--- Not Used ---		C2
Z05	--- Not Used ---		C2

PC Board D 8688-0 REF MAIN

8 Module Information

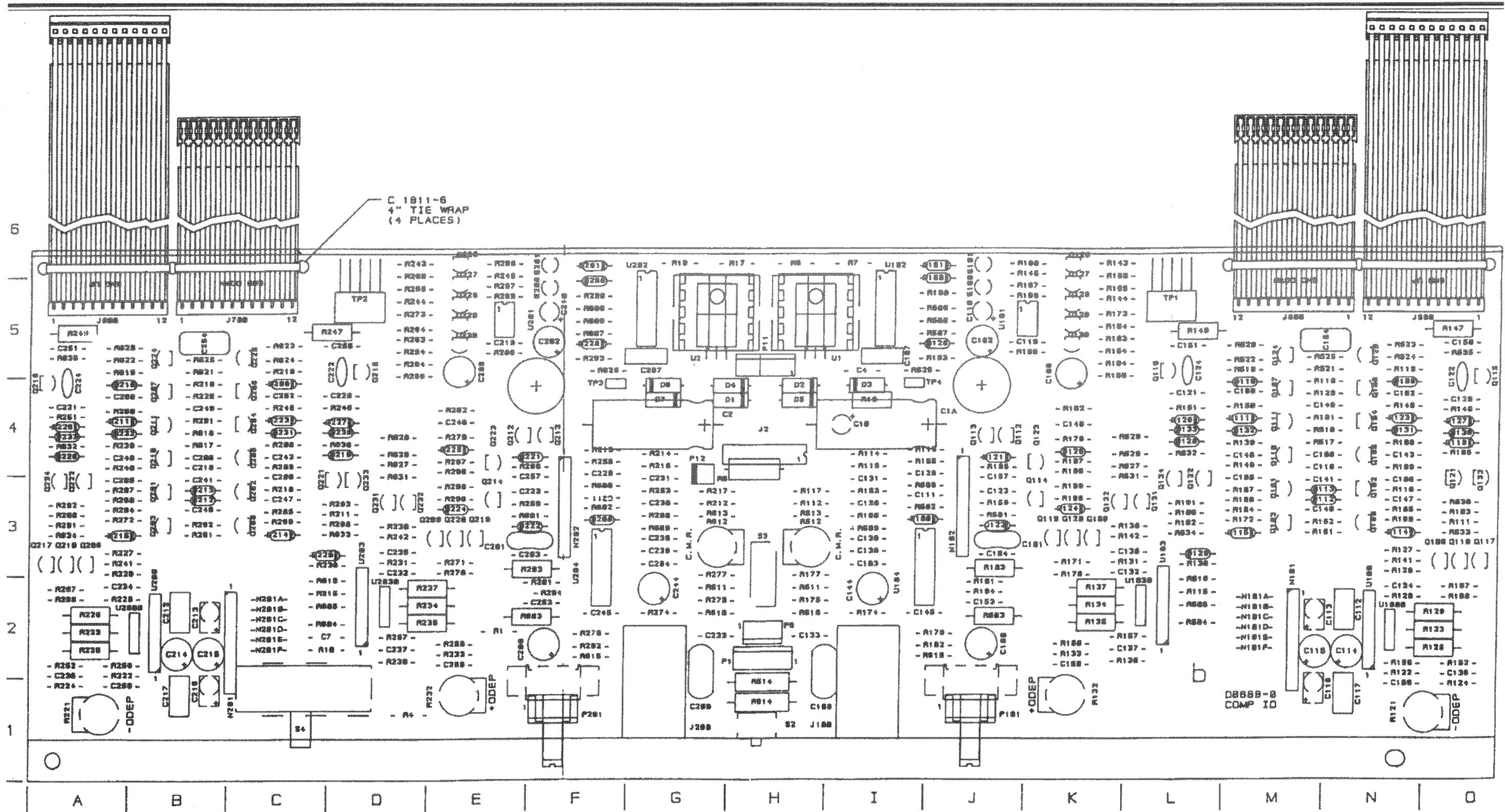

Figure 8.7 Q43311-2 Main Module Map

8 Module Information

8.11 D43388-0 Main Module Parts List

<u>Cir. Des.</u>	<u>C.P.N.</u>	<u>Description</u>	<u>Man Loc</u>
C1	C 5362-6	2.2uF 50V	I4
C2	C 3913-8	470uF 35V	G4
C4	C 6802-0	.47uF 50V	I5
C7	C 6804-6	.1uF 35V	D2
C1A	--- Not Used ---		I4
C100/200	C 8576-8	100uF 35V	J2/F2
C101/201	C 8338-3	47pF 300V	J3/E2
C102/202	C 8576-8	100uF 35V	J5/F5
C103/203	C 6805-3	.022uF 100V	I3/F3
C104/204	C 6805-3	.022uF 100V	J3/G3
C105/205	C 6813-7	27pF 200V	M3/A3
C106/206	C 6813-7	27pF 200V	N3/C3
C107/207	C 7870-6	.39uF 63V	I5/G5
C108/208	C 6813-7	27pF 200V	N4/B4
C109/209	C 8576-8	100uF 35V	K5/E5
C110/210	C 5362-6	2.2uF 50V	J5/F5
C111/211	C 6807-9	.001uF 100V	J3/F3
C112/212	C 8990-1	.18uF 63V	N2/B2
C113/213	C 8989-3	6.8uF 50V	N2/B2
C114/214	C 8576-8	100uF 35V	N2*/B2*
C115/215	C 8576-8	100uF 35V	N1/B1
C116/216	C 8989-3	6.8uF 50V	N1/B1
C117/217	C 8990-1	.18uF 63V	M1/B1
C118/218	C 6813-7	27pF 200V	N4/B4
C119/219	C 6802-0	.47uF 50V	J5/F5
C120/220	C 6804-6	.1uF 50V	O4/D4
C121/221	C 6804-6	.1uF 50V	L4/A4
C122/222	C10176-3	33pF 200V	O4/D5
C123/223	C 6808-7	470pF 100V	J3/F3
C124/224	C10176-3	33pF 200V	L5/A4
C129/229	C 6812-9	47pF 100V	J4/F3
C130/230	C 6814-5	12pF 200V	J5/F5
C131/231	C 6814-5	12pF 200V	J4/F5
C132/232	C 6806-1	.01uF 100V	L3/D3
C133/233	C 6813-7	27pF 200V	H2/G2
C134/234	C 6805-3	.022uF 100V	N2/A2
C135/235	C 6805-3	.022uF 100V	L3/D3
C136/236	C 6808-7	470pF 100V	O2/A2
C137/237	C 6808-7	470pF 100V	L2/D2
C138/238	C 6812-9	47pF 100V	I3/G3
C139/239	C 6812-9	47pF 100V	I3/G3
C140/240	C 6814-5	12pF 200V	N3/B3
C141/241	C 6814-5	12pF 200V	N3/B3
C143/243	C 6808-7	470pF 100V	N4/C4
C144/244	C 8576-8	100uF 35V	I2/G2
C145/245	C 6812-9	47pF 100V	J2/F2
C146/246	C 6812-9	47pF 100V	J3/F3
C147/247	--- Not Used ---		N3/C3
C148/248	C 6808-7	470pF 100V	M4/A4
C149/249	C 6807-9	.001uF 100V	N4/B4
C150/250	--- Not Used ---		O5/D5
C151/251	C 6806-1	.01uF 100V	L5/A5
C152/252	C 6811-1	100pF 200V	N4/C4
C153/253	C 6804-6	.1uF 50V	J2/F2
C154/254	C 8426-6	.1uF 250V	N5/B5
C155/255	C 6804-6	.1uF 50V	K2/E2
C156/256	C 6804-6	.1uF 50V	N1/A1
C157/257	C 6813-7	27pF 200V	J3/F3
C159/259	C 8551-1	.01uF 400V	I2/G2
C160/260	C 6811-1	100pF 200V	M4/A4
C161/261	C10176-3	33pF 200V	O4/C5
C162/262	C10176-3	33pF 200V	L5/A4
D1	C 2851-1	1N4004	H4
D2	C 2851-1	1N4004	H4
D3	C 2851-1	1N4004	I4
D4	C 2851-1	1N4004	H4
D5	C 2851-1	1N4004	H4
D6	C 2851-1	1N4004	G4
D7	C 2851-1	1N4004	G4
D100/200	C 3181-2	1N4148	J6/F6
D101/201	C 3181-2	1N4148	J6/F6
D108/208	C 3181-2	1N4148	J2/F3
D109/209	C 3181-2	1N4148	N4/C4
D110/210	C 3181-2	1N4148	M4/A4
D111/211	--- Not Used ---		M4/A4
D112/212	C 3181-2	1N4148	N3/B3
D113/213	C 3181-2	1N4148	N3/B3
D114/214	C 8158-5	1SS143	N3/C3
D115/215	C 8158-5	1SS143	M3/A3
D119/219	C 3181-2	1N4148	O4/D4
D120/220	C 3181-2	1N4148	L4/A4
D121/221	C 3824-7	1N9708	J4/E4
D122/222	C 3181-2	1N4148	J3/F3
D123/223	--- Not Used ---		N4/C4
D124/224	C 3181-2	1N4148	K3/E3
D125/225	C 3181-2	1N4148	K4/E4
D126/226	C 8158-5	1SS143	L4/A4
D127/227	C 8158-5	1SS143	O4/D4
D128/228	C 3181-2	1N4148	J5/F5
D129/229	C 5061-4	1N3070	L3/D3
D130/230	C 3181-2	1N4148	O4/D4
D131/231	C 3181-2	1N4148	N4/C4
D132/232	C 3181-2	1N4148	M4/A4
D133/233	C 3181-2	1N4148	L4/A4
D134/234	C 2851-1	1N4004	K4/E4
D135/235	C 2851-1	1N4004	K5/E4

*For board D 8920-7 C114 map location is M2, and C214 is C2.

8 Module Information

E100/200	C 9857-1	Red LED	J5/F5	Q121/221	C 7458-0	2N4123	O4/D4
E101/201	C 9857-1	Red LED	J6/F6	Q122/222	C 3625-8	2N4125	L3/A3
HW16	C 1812-7	5.5" Cable Tie	O5	Q123/223	C 3625-8	2N4125	K4/E4
HW17	C 1812-7	5.5" Cable Tie	N5	Q124/224	--- Not Used ---	---	M5/B5
HW18	C 1812-7	5.5" Cable Tie	B5	Q125/225	--- Not Used ---	---	N5/C5
HW19	C 1812-7	5.5" Cable Tie	A5	Q126/226	C 3625-8	2N4125	K6/E6
J2	C 4508-5	16 Pin IC Skt.	H4	Q127/227	C 7458-0	2N4123	K6/E6
J100/200	C 8432-4	3 Cond Ph Jk	I1/G1	Q128/228	C 3625-8	2N4125	K5/E5
J100X/200XC	6778-2	Ph Jk Cover	I1/G1	Q129/229	C 7458-0	2N4123	K5/E5
J500	D 8395-2	7.75" 12pin Cbl	O5	Q130/230	C 3625-8	2N4125	K5/E5
J600	D 8397-8	2.5" 12pin Cbl	N5	Q131/231	C 3625-8	2N4125	L3/D3
J700	D 8397-8	2.5" 12pin Cbl	B5	Q132/232	C 3625-8	2N4125	K3/D3
J800	D 8395-2	7.75" 12pin Cbl	A5	Q133/233	C 3625-8	2N4125	O4/D4
N101/201	D 7946-3	Res Net-ODEP	M2/C2	Q134/234	C 7458-0	2N4123	L3/A3
N102/202	D 6082-8	Res Net-C	J4/E4	Q135/235	C 3810-6	MPSA42	K4/E4
N101A/201A	--- Not Used ---	---	---	Q136/236	C 3578-9	MPSA93	K4/D5
N101B/201B	--- Not Used ---	---	---	R1	A10265-10021	10K 1%	E2
N101C/201C	--- Not Used ---	---	---	R4	A10265-10521	10.5K 1%	D1
N101D/201D	--- Not Used ---	---	---	R5	--- Not Used ---	---	H4
N101E/201E	--- Not Used ---	---	---	R7	A10266-4331	43K 5%	I6
N101F/201F	--- Not Used ---	---	---	R8	A10265-75021	75K 1%	H6
P1	C 7593-4	5pos Header	H2	R10	--- Not Used ---	---	D2
P6	C 8418-3	3pos Header	H2	R11	--- Not Used ---	---	L5
P11	C 7593-4	5pos Header	H5	R12	--- Not Used ---	---	D5
P12	--- Not Used ---	---	---	R17	A10265-75021	75K 1%	H6
P101/201	C 7592-6	4pos Header	J1/F1	R18	A10266-4331	43K 5%	G6
Q100/200	D 2961-7	2961	N3/C3	R19	A10266-2R72	2.7 5% .5W	I4
Q101/201	C 8104-9	MPSW92	M3/B3	R100/200	--- Not Used ---	---	I3/G3
Q102/202	C 8103-1	MPSW42	N3/C3	R101/201	A10265-10211	1.02K 1%	J2/F2
Q103/203	C 3625-8	2N4125	M3/B3	R102/202	A10266-5111	510 5%	J3/F3
Q104/204	C 8104-9	MPSW92	N4/C4	R103/203	A10265-20523	20.5K 1% 1W	J2/F2
Q105/205	C 8104-9	MPSW92	N4/C4	R104/204	A10265-26711	2.67K 1%	M3/A3
Q106/206	C 3625-8	2N4125	O3/A3	R105/205	A10265-26711	2.67K 1%	N3/C3
Q107/207	C 3786-8	MPS4250A	M4/B4	R106/206	A10265-11821	11.8K 1%	L3/A3
Q108/208	C 5891-4	MTS105 Therm	N4/C4	R107/207	A10266-6831	68K 5%	M3/A3
Q109/209	D 2961-7	2961	K3/E3	R108/208	A10266-8211	820 5%	N4/C4
Q110/210	C 8103-1	MPSW42	M4/B4	R109/209	A10266-1111	110 5%	N4/C4
Q111/211	C 8103-1	MPSW42	M4/B4	R110/210	A10266-6831	68K 5%	N3/C3
Q112/212	C 3625-8	2N4125	J4/E4	R111/211	A10265-11821	11.8 1%	O3/D3
Q113/213	C 3625-8	2N4125	J4/F4	R112/212	A10265-49921	49.9K 1%	H3/G3
Q114/214	C 7458-0	2N4123	K3/E3	R113/213	A10265-48711	4.87K 1%	J4/F4
Q115/215	D 2962-5	MPSA18	O5/D5	R114/214	A10266-1521	1.5K 5%	I4/G4
Q116/216	C 3786-8	MPS4250A	L5/A5	R115/215	A10266-5141	510K 5%	L2/D2
Q117/217	D 2961-7	2961	O3/A3	R116/216	A10266-3351	3.3M 5%	J4/F4
Q118/218	D 2961-7	2961	O3/A3	R117/217	A10266-4731	47K 5%	H3/G3
Q119/219	C 3625-8	2N4125	K3/E3	R118/218	A10265-68101	681 1%	N4/B4
Q120/220	C 3625-8	2N4123	K3/E3	R119/219	A10265-12111	1.21K 1%	N5/C5
				R120/220	A10265-68101	681 1%	N4/B4
				R121/221	C 5062-2	100K LIN POT	O1/A1
				R122/222	A10266-2741	270K 5%	N2/A2
				R123/223	A10266-2032	20K 5% .5W	O2/A2

8 Module Information

R124/224	A10266-6821	6.8K 5%	O1/A1	R176/276	A10265-11821	11.8K 1%	J2/F2
R125/225	A10266-1011	100 5%	O2/A2	R177/277	A10265-13321	13.3K 1%	H3/G3
R126/226	A10266-1011	100 5%	O2/A2	R179/279	A10266-1321	1.3K 5%	K4/E4
R127/227	A10266-6821	6.8K 5%	N3/A3	R180/280	A10266-4711	470 5%	M3/A3
R128/228	A10266-1331	13K 5%	N2/A2	R181/281	A10265-48711	4.87K 1%	N4/B4
R129/229	A10266-1041	100K 5%	N3/A3	R182/282	A10266-2201	22 5%	J2/F2
R130/230	A10266-1041	100K 5%	L3/D3	R183/283	A10266-4731	47K 5%	O3/D3
R131/231	A10266-1331	13K 5%	L3/D3	R184/284	A10266-4741	470K 5%	K5/D5
R132/232	C 5062-2	100K LIN POT	K1/E1	R185/285	A10266-4731	47K 5%	O4/D3
R133/233	A10266-2741	270K 5%	K2/E2	R186/286	A10266-2751	2.7M 5%	J5/F5
R134/234	A10266-2032	20K 5% .5W	M3/C3	R187/287	A10266-3321	3.3K 5%	K6/E6
R135/235	A10266-1011	100 5%	K2/E2	R188/288	A10266-3321	3.3K 5%	K6/E6
R136/236	A10266-6821	6.8K 5%	L2/D2	R189/289	A10266-2731	27K 5%	K5/E5
R137/237	A10266-1011	100 5%	K2/E2	R190/290	A10266-2051	2M 5%	J5/F6
R138/238	A10266-6821	6.8K 5%	L3/D3	R191/291	A10266-4731	47K 5%	L3/A3
R139/239	A10266-8211	820 5%	M4/A4	R192/292	A10266-4731	47K 5%	L3/A3
R140/240	A10266-1111	110 5%	M4/A4	R193/293	A10265-10021	10K 1%	J5/F5
R141/241	A10266-1541	150K 5%	N3/A3	R194/294	A10265-20021	20K 1%	J2/F2
R142/242	A10266-1541	150K 5%	L3/D3	R195/295	A10266-4701	47 5%	K4/F3
R143/243	A10266-4711	470 5%	K6/D6	R196/296	A10266-3921	3.9K 5%	K4/E4
R144/244	A10266-4711	470 5%	K5/D5	R197/297	A10265-10021	10K 1%	K4/E4
R145/245	A10266-4711	470 5%	J6/E6	R198/298	A10266-3921	3.9K 5%	K3/E3
R146/246	A10265-11821	11.8K 1%	O4/D4	R199/299	A10265-10021	10K 1%	K3/E3
R147/247	C 5868-2	0 OHM	O5/D5	R500/600	A10266-3041	300K 5%	J3/F3
R148/248	A10265-20011	2K 1%	N4/C4	R501/601	A10266-3041	300K 5%	J3/F3
R149/249	A10266-1012	100 5% .5W	L5/A5	R502/602	A10266-3041	300K 5%	J3/F3
R150/250	A10265-20011	2K 1%	M4/A4	R503/603	A10266-4702	47 5% .5W	J2/F2
R151/251	A10265-11821	11.8K 1%	L4/A4	R504/604	A10266-5141	510K 5%	L2/D2
R152/252	A10265-11821	11.8K 1%	O2/A2	R505/605	A10266-5141	510K 5%	L2/D2
R153/253	A10124-24	#24 Buss Wire	J4/G3	R506/606	A10266-1521	1.5K 5%	J5/F5
R154/254	A10266-5601	56 5%	K5/D5	R507/607	A10266-4711	470 5%	J5/F5
R155/255	A10266-4731	47K 5%	J4/F4	R508/608	A10266-2731	27K 5%	J5/F5
R156/256	A10266-1321	1.3K 5%	N2/A2	R509/609	A10265-49911	4.99K 1%	I3/G3
R157/257	A10266-1321	1.3K 5%	L2/D2	R510/610	A10265-49911	4.99K 1%	H2/G2
R158/258	A10266-9121	9.1K 5%	K2/E2	R511/611	A10265-49911	4.99K 1%	H2/G2
R159/259	A10266-1331	13K 5%	J3/F3	R512/612	C 9079-2	200/220 Pot	H3/H3
R160/260	A10266-5601	56 5%	K6/D6	R513/613	A10265-49911	4.99K 1%	H3/G3
R161/261	A10266-4701	47 5%	N3/B3	R514/614	C 7340-0	24 5% 3W	H1/H1
R162/262	A10266-4701	47 5%	N3/B3	R515/615	A10266-1821	1.8K 5%	J1/F1
R163/263	A10266-5601	56 5%	K5/D5	R516/616	A10266-1051	1M 5%	L2/D2
R164/264	A10266-4711	470 5%	K5/D5	R517/617	A10266-1111	110 5%	N4/B4
R165/265	A10266-4711	470 5%	K5/D6	R518/618	A10266-1111	110 5%	N4/B4
R166/266	A10266-4711	470 5%	K5/D5	R519/619	A10265-12111	1.21K 1%	M5/A5
R167/267	A10265-10011	1K 1%	O2/A2	R520/620	--- Not Used ---		M5/A5
R168/268	A10265-95301	953 1%	O2/A2	R521/621	--- Not Used ---		N5/B5
R169/269	A10266-1041	100K 5%	N3/C3	R522/622	--- Not Used ---		M5/A5
R170/270	A10265-10011	1K 1%	K3/E3	R523/623	--- Not Used ---		N5/C5
R171/271	A10265-95301	953 1%	K3/E3	R524/624	--- Not Used ---		N5/C5
R172/272	A10266-1041	100K 5%	M3/A3	R525/625	--- Not Used ---		N5/B5
R173/273	A10266-5601	56 5%	K5/D5	R526/626	A10265-10021	10K 1%	I5/F5
R174/274	A10265-11821	11.8K 1%	I2/G2	R527/627	A10266-3921	3.9K 5%	L4/D4
R175/275	A10265-48711	4.87K 1%	H2/G2	R528/628	A10265-10021	10K 1%	L4/D4

8 Module Information

R529/629	A10266-4731	47K 5%	L4/D4	U1	C 5095-2	MC7815CT	H5
R530/630	A10265-10021	10K 1%	O3/D4	U1X	C 9494-3	Heatsink	H5
R531/631	A10266-4731	47K 5%	L3/D3	U2	C 5096-0	MC7915CT	G5
R532/632	A10265-10021	10K 1%	L4/A4	U2X	C 9494-3	Heatsink	G5
R533/633	A10265-10021	10K 1%	O3/D3	U100/200	C 6911-9	UPA75	N2/B2
R534/634	A10265-10021	10K 1%	L3/A3	U101/201	C 6411-0	H11C2	J5/E5
R535/635	A10266-1R01	1 5%	O5/A5	U101X/201X	C 8019-9	6 pin IC Skt	J5/E5
R536/636	A10266-4701	47 5%	K5/E5	U102/202	C 4345-2	LM339N	I5/G5
R537/637	A10266-1031	10K 5%	K4/D4	U102X/202X	C 3450-1	14 pin IC Skt	I5/G5
R538/638	A10266-1031	10K 5%	L4/D5	U103/203	C 6910-1	UPA76	L2/D2
R539/639	--- Not Used ---	---	J1/F1	U104/204	C 7558-7	MC33079P	I3/F3
R540/640	--- Not Used ---	---	J1/E1	U104X/204X	C 3450-1	14 pin IC Skt	I3/F3
R541/641	--- Not Used ---	---	I2/G2	U100B/200B	--- Not Used ---	---	N2/B2
R542/642	--- Not Used ---	---	I3/G3	U103B/203B	--- Not Used ---	---	L2/D2
R543/643	--- Not Used ---	---	J5/F5	Z7	--- Not Used ---	---	G4
R544/644	A10266-2031	20K 5%	L4/E4	Z8	--- Not Used ---	---	H4
R545/645	A10266-2031	20K 5%	M4/D4	Z9	--- Not Used ---	---	B1
S2	C 7325-1	DPDT Switch	H1	Z01	--- Not Used ---	---	D1
S3	C 7960-5	3 Pos Switch	H2	Z02	--- Not Used ---	---	C1
S4	C 6781-6	6P3T Switch	C1	Z03	--- Not Used ---	---	C1
TP1	C 6564-6	10P Header	L5	Z04	--- Not Used ---	---	C2
TP2	C 6564-6	10P Header	D5	Z05	--- Not Used ---	---	C2
TP3	C 9896-9	Test Point	F4	Z10	--- Not Used ---	---	B2
TP4	C 9896-9	Test Point	I4	Z11	--- Not Used ---	---	M1

PC Board D 8825-8 or D 8920-7

8 Module Information

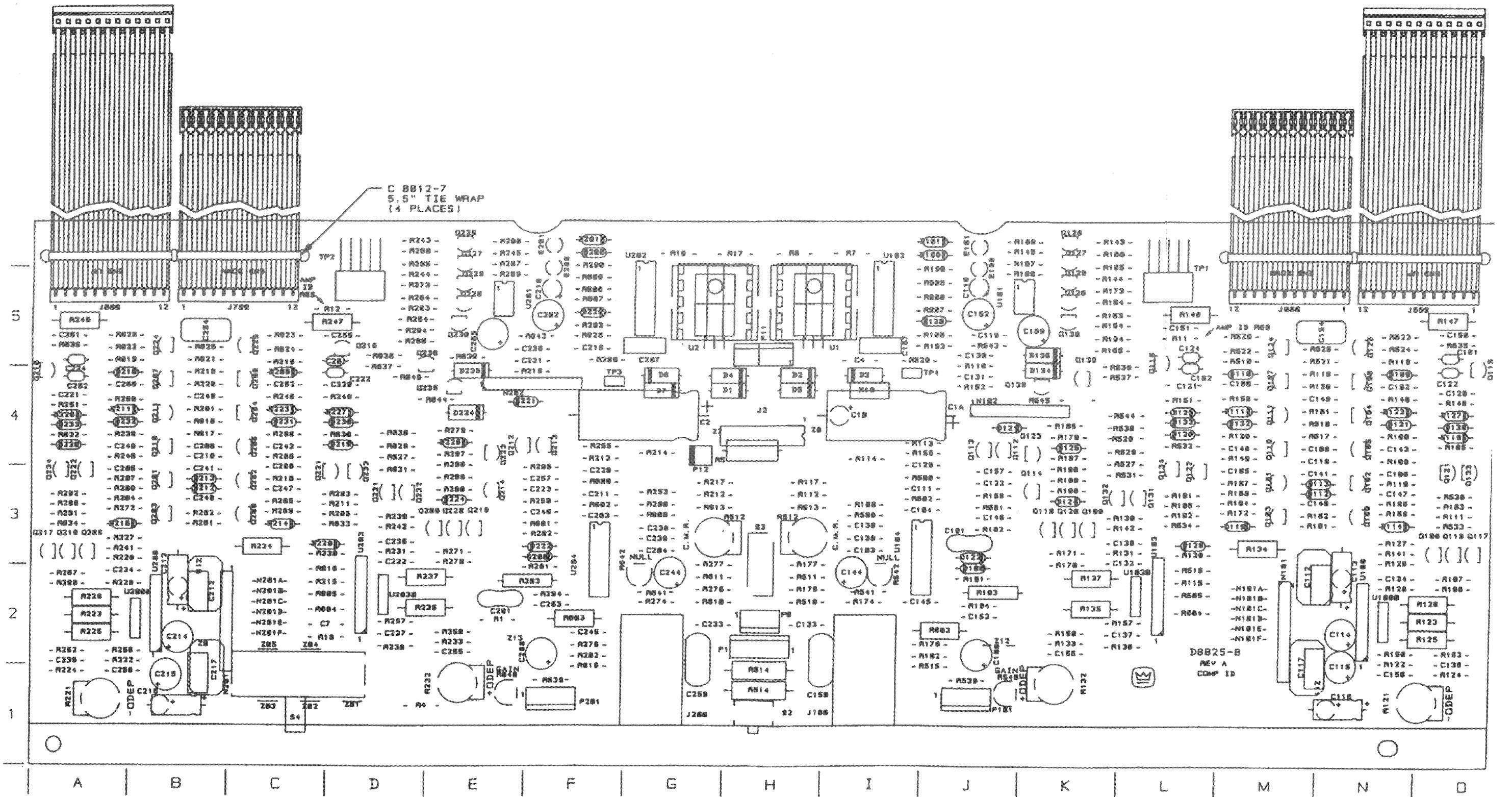

Figure 8.8 Q43388-0 Main Module Map

8 Module Information

8.12 Q43389-8 Output Module Parts List

<u>Cir. Des.</u>	<u>C.P.N.</u>	<u>Description</u>	<u>Map Loc</u>				
C01	A10434-473JD	.047 μ F 250V	G1	P00	---	Not Used	---
C02	C 8426-6	.1 μ F 250V	C2	P500	C 9828-2	12 Pin Header	E3
C03	C 8426-6	.1 μ F 250V	L2	P600	C 9828-2	12 Pin Header	J3
C04	C 8524-7	.0047 μ F 100V	F4	Q00	C 4647-1	TIP47 NPN	I4
C05	C 6806-1	.01 μ F 100V	J4	Q01	C 8574-3	2SC2837 NPN	E5
C06	C 6806-1	.01 μ F 100V	G4	Q05	C 8573-5	2SA1186 PNP	J5
C07	C 6807-9	.001 μ F 100V	F3	Q12	C 8574-3	2SC2837 NPN	G5
C08	C 6810-3	180pF 100V	E3	Q16	C 8573-5	2SA1186 PNP	H5
C09	C 6809-5	220pF 100V	J3	Q17	C10155-7	2SC4793 NPN	F4
C10	C 6807-9	.001 μ F 100V	I4	Q18	C 4647-1	TIP47 NPN	F4
C11	---	Not Used	I4	Q19	C10156-5	2SA1837 PNP	I4
C12	---	Not Used	I4	R00	A10266-6801	68.5%	F4
C13	---	Not Used	G2	R01	A10266-1011	100.5%	E4
C13A	C 8991-9	.47 μ F 63V	D3	R02	C 7778-1	5.6.5%.5W FP	F3
C15	C 6811-1	100pF 200V	F3	R03	C 6486-2	.2.5%.5W	E2
C16	C 8426-6	.1 μ F 250V	H4	R04	C 6486-2	.2.5%.5W	C2
D01	C 2851-1	1N4004	E3	R05	C 6486-2	.2.5%.5W	A1
D02	C 2851-1	1N4004	F3	R06	C 6486-2	.2.5%.5W	I2
D03	C 2851-1	1N4004	I3	R07	C 6486-2	.2.5%.5W	K2
D04	C 2851-1	1N4004	J3	R08	C 6486-2	.2.5%.5W	N1
D05	C 2941-0	1N5402	A2	R09	C 7779-9	22.5% FP	J3
D06	C 2941-0	1N5402	M2	R10	A10266-1011	100.5%	J4
D07	C 2941-0	1N5402	B3	R11	C 6625-5	5.6.5%.5W	H2
D08	C 2941-0	1N5402	K2	R12	A10266-2R74	2.7.5%.2W	C1
D15	C 2851-1	1N4004	A2	R13	A10266-6801	68.5%	J4
D16	C 2851-1	1N4004	N3	R14	A10266-2R74	2.7.5%.2W	M1
HW1	A10094-2	#4 Lockwasher		R15	C 6486-2	.2.5%.5W	M1
HW2	A10094-2	#4 Lockwasher		R16	C 6486-2	.2.5%.5W	E2
HW3	A10094-2	#4 Lockwasher		R17	C 6486-2	.2.5%.5W	F1
HW4	A10094-2	#4 Lockwasher		R18	C 6486-2	.2.5%.5W	B1
HW5	C 7481-2	4 Way Conn.		R19	C 6486-2	.2.5%.5W	J1
HW6	C 7481-2	4 Way Conn.		R20	C 6486-2	.2.5%.5W	H1
HW7	A10608-3	4-40X3/8 Spcr		R21	C 7778-1	5.6.5%.5W FP	F1
HW8	A10608-3	4-40X3/8 Spcr		R22	C 7779-9	22.5% FP	H3
HW9	A10608-3	4-40X3/8 Spcr		R23	C 6844-2	250 Pot	H3
HW10	A10608-3	4-40X3/8 Spcr		R24	A10266-1331	13K 5%	F4
HW11	D 8441-4	Fishpaper		R25	A10266-2221	2.2K 5%	F3
HW12	A10020-1	4-40X.25 Stud		R26	C 6844-2	250 Pot	G4
HW13	A10020-1	4-40X.25 Stud		R27	A10266-3911	390.5%	G4
HW14	A10020-1	4-40X.25 Stud		R28	A10266-1331	13K 5%	I4
HW15	A10020-1	4-40X.25 Stud		R29	A10266-5101	51.5%	F3
L00	D 7701-2	2.5 μ H Coil		R30	A10265-10201	102.1%	D3
L01	C 3510-2	470 μ H Choke	F4	R31	C 6625-5	5.6.5%.5W	G2
L02	C 3510-2	470 μ H Choke	J4	R35	A10266-1R02	1.5%.5W	D4
				R36	A10266-1R02	1.5%.5W	K4
				R37	C 7779-9	22.5% FP	D3
				R38	C 7779-9	22.5% FP	D2
				R39	C 7779-9	22.5% FP	D3
				R40	C 7779-9	22.5% FP	K3
				R41	C 7779-9	22.5% FP	K3

8 Module Information

R42	C 7779-9	22 5% FP	J3
R43	A10266-5101	51 5%	G4
R44	A10266-2221	2.2K 5%	H3
R45	A10266-7511	750 5%	I4
R49	C 7779-9	22 5% FP	F2
R50	C 7779-9	22 5% FP	D2
R51	C 7779-9	22 5% FP	B2
R52	C 7779-9	22 5% FP	M2
R53	C 7779-9	22 5% FP	K2
R54	C 7779-9	22 5% FP	I2
Z3	C 5868-2	0 Ohm Jmp	D1
Z4	C 5868-2	0 Ohm Jmp	D3
Z8	C 5868-2	0 Ohm Jmp	D2
Z00	C 5868-2	0 Ohm Jmp	E1
Z01	C 5868-2	0 Ohm Jmp	E2
Z02	C 5868-2	0 Ohm Jmp	E3
Z03	C 5868-2	0 Ohm Jmp	E3
Z04	C 5868-2	0 Ohm Jmp	H3
Z05	C 5868-2	0 Ohm Jmp	H3
Z06	C 5868-2	0 Ohm Jmp	H3
Z07	C 5868-2	0 Ohm Jmp	I3
Z08	C 5868-2	0 Ohm Jmp	J3
Z09	C 5868-2	0 Ohm Jmp	J3
Z10	C 5868-2	0 Ohm Jmp	J2
Z11	C 5868-2	0 Ohm Jmp	J1
Z12	C 5868-2	0 Ohm Jmp	J2
Z13	C 5868-2	0 Ohm Jmp	J1
Z14	C 5868-2	0 Ohm Jmp	E3
Z16	C 5868-2	0 Ohm Jmp	E3
Z17	C 5868-2	0 Ohm Jmp	H1
Z18	C 5868-2	0 Ohm Jmp	H1
PC Board	P10423-5	THC #2	

8 Module Information

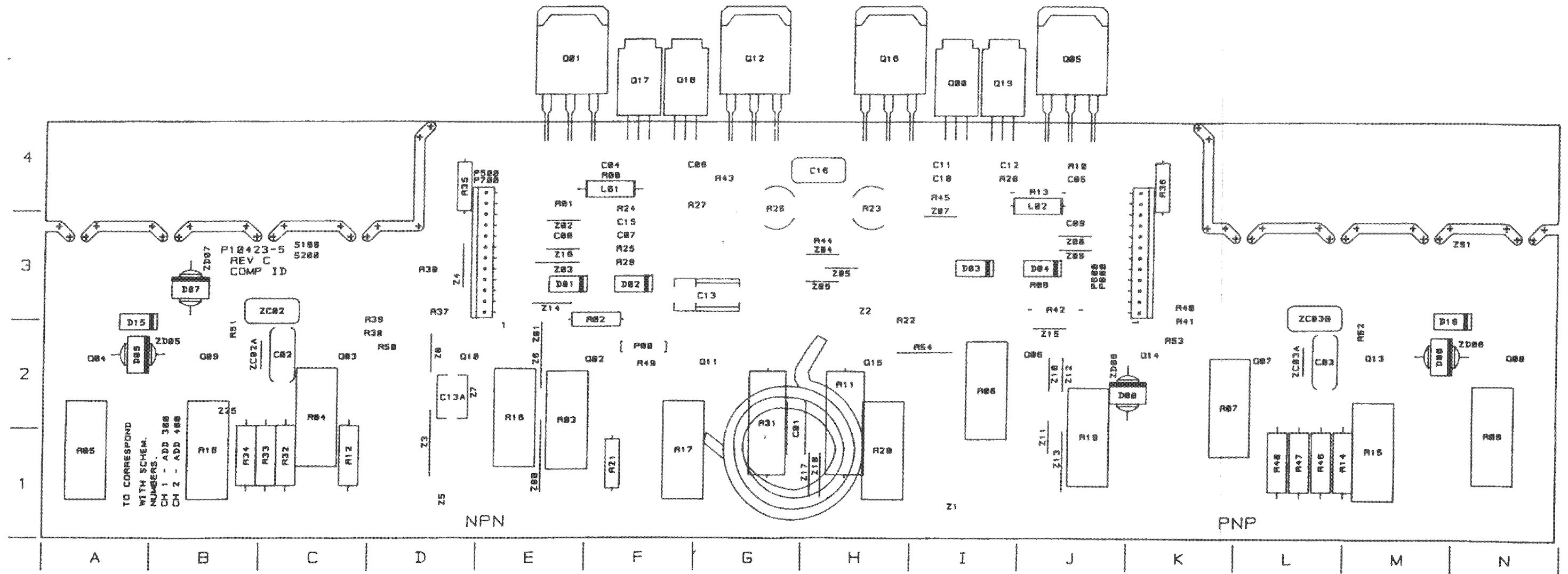

Figure 8.9 Q43389-8 Output Module Map

8 Module Information

8.13 Q43312-0 Display Module Parts List

Cir. Des.	C.P.N.	Description	Map Loc	E8	C10592-1	Green LED	K1
C1	C 6813-7	27pF 200V	B2	E9	C10592-1	Green LED	J1
C2	C 6813-7	27pF 200V	B1	E10	C10592-1	Green LED	L1
C3	C 6802-0	.47µF 50V	B3	E11	C10592-1	Green LED	I1
C4	C 6802-0	.47µF 50V	B2	E12	C10592-1	Green LED	L1
C5	C 6804-6	.1µF 50V	E2	E13	C10592-1	Green LED	I1
C6	C 6804-6	.1µF 50V	E2	E14	C10592-1	Green LED	L1
C7	C 6804-6	.1µF 50V	E2	E15	C10592-1	Green LED	I2
C8	C 6804-6	.1µF 50V	E2	E16	C10592-1	Green LED	L2
C9	C 6804-6	.1µF 50V	E2	E17	C 4342-9	Amber LED	N2
C10	C 6804-6	.1µF 50V	E2	J3	D 6990-2	16 pin cable	D2
C11	C 6804-6	.1µF 50V	E1	P12	D 6990-2	16 pin cable	F2
C12	C 6804-6	.1µF 50V	C3	Q1	C 3625-8	2N4125	J2
C13	C 6804-6	.1µF 50V	C2	Q2	C 3625-8	2N4125	L2
C14	C 6804-6	.1µF 50V	C1	R1	A10265-10031	100K 1%	A2
C15	C 6802-0	.47µF 50V	A3	R2	A10265-10031	100K 1%	A1
C16	C 6802-0	.47µF 50V	A1	R7	A10265-10031	100K 1%	A2
C17	C 6807-9	.001µF 100V	C2	R8	A10265-10031	100K 1%	A1
C18	C 6807-9	.001µF 100V	C2	R9	A10265-10021	10K 1%	A2
C19	C 6807-9	.001µF 100V	E2	R10	A10265-10021	10K 1%	A1
C20	C 6807-9	.001µF 100V	E2	R11	A10265-49911	4.99K 1%	B2
C21	C 6807-9	.001µF 100V	E2	R12	A10265-49911	4.99K 1%	A1
C22	C 6807-9	.001µF 100V	E1	R13	A10265-82511	8.25K 1%	C2
C23	C 6807-9	.001µF 100V	E1	R15	A10265-14321	14.3K 1%	C2
C24	C 6807-9	.001µF 100V	E1	R17	A10265-82511	8.25K 1%	C2
C25	C 6807-9	.001µF 100V	C1	R19	A10266-8211	820 5%	J2
C26	C 6807-9	.001µF 100V	C1	R20	A10266-8211	820 5%	L2
C27	C 6804-6	.1µF 50V	K2	R21	A10265-10021	10K 1%	B2
C28	C 6804-6	.1µF 50V	L2	R22	A10265-10021	10K 1%	B1
D1	C 3181-2	1N4148	A2	R23	A10266-5121	5.1K 5%	B3
D2	C 3181-2	1N4148	A1	R24	A10266-5121	5.1K 5%	B2
D3	C 3181-2	1N4148	A2	R25	A10266-8211	820 5%	K2
D4	C 3181-2	1N4148	A1	R26	A10266-8211	820 5%	L2
D5	C 3181-2	1N4148	G2	R27	A10266-1851	1.8M 5%	B2
D6	C 3181-2	1N4148	M1	R28	A10266-1851	1.8M 5%	B1
D7	C 3181-2	1N4148	I2	R29	A10265-68111	6.81K 1%	D2
D8	C 3181-2	1N4148	L2	R30	A10265-68111	6.81K 1%	E1
D9	C 3181-2	1N4148	B2	R31	A10265-16911	1.69K 1%	D2
D10	C 3181-2	1N4148	B1	R32	A10265-16911	1.69K 1%	E1
D11	C 3181-2	1N4148	J2	R33	A10265-95301	953 1%	D2
D12	C 3181-2	1N4148	L2	R34	A10265-95301	953 1%	D1
E1	C 4431-0	Yellow LED	I2	R35	A10265-53601	563 1%	D2
E2	C 4431-0	Yellow LED	L2	R36	A10265-53601	536 1%	D1
E3	C10592-1	Green LED	J2	R37	A10266-3011	300 5%	D2
E4	C10592-1	Green LED	L2	R38	A10266-3011	300 5%	D1
E5	C10592-1	Green LED	J1	R39	A10266-3911	390 5%	D2
E6	C10592-1	Green LED	K1	R40	A10266-3911	390 5%	D1
E7	C10592-1	Green LED	J1	R41	A10266-2231	22K 5%	B2

8 Module Information

R42	A10266-2231	22K 5%	C1	R71	A10266-8211	820 5%	I2
R43	A10266-2231	22K 5%	C2	R72	A10266-8211	820 5%	M1
R44	A10266-2231	22K 5%	B1	R73	A10266-1821	1.8K 5%	I2
R45	A10266-2231	22K 5%	E2	R74	A10266-1821	1.8K 5%	M1
R46	A10266-2231	22K 5%	E1	R75	A10266-3321	3.3K 5%	I2
R47	A10266-2231	22K 5%	E2	R76	A10266-3321	3.3K 5%	L1
R48	A10266-2231	22K 5%	E1	R77	A10265-12121	12.1K 1%	G1
R49	A10266-2231	22K 5%	E2	R78	C 3670-4	5K Pot	G1
R50	A10266-2231	22K 5%	E1	R79	A10266-4741	470K 5%	K2
R51	A10266-3911	390 5%	K2	R80	A10266-4741	470K 5%	L1
R52	A10266-3911	390 5%	K1	R81	A10266-1521	1.5K 5%	I2
R53	A10266-3911	390 5%	K2	R82	A10266-1521	1.5K 5%	L2
R54	A10266-3911	390 5%	K1	S1	C 7325-1	DPDT	G1
R55	A10266-3911	390 5%	K2	S2	C 7325-1	DPDT	F1
R56	A10266-3911	390 5%	L1	U1	C 7558-7	MC33079	B2
R57	A10266-3911	390 5%	J2	U2	C 7558-7	MC33079	B1
R58	A10266-3911	390 5%	L1	U3	C 4345-2	LM339	C2
R59	A10266-3911	390 5%	J2	U4	C 4345-2	LM339	C1
R60	A10266-3911	390 5%	L1	U5	C 4345-2	LM339	F2
R61	A10266-1051	1M 5%	E2	U6	C 4345-2	LM339	F1
R62	A10266-1051	1M 5%	D1	Z1	--- Not Used ---		G1
R63	A10266-3351	3.3M 5%	E2	Z2	--- Not Used ---		G1
R64	A10266-3351	3.3M 5%	D1				
R66	A10266-4731	47K 5%	F1	1	D 7940-6	Display Board	
R68	A10266-1021	1K 5%	F1				
R69	A10266-5151	5.1M 5%	A2				
R70	A10266-5151	5.1M 5%	A1				

8 Module Information

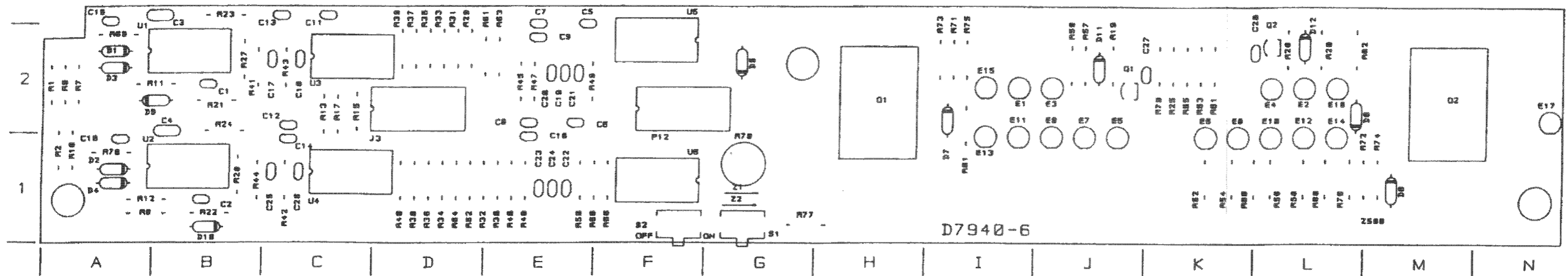

Figure 8.10 Q43312-0 Display Module Map